

Date: 21 Jan 2008

Subject: FDE (N) Models when combining with RC-E3 Wall Remote Controller

Please be advised that **FDEN** model by definition come factory installed with an Infrared receiver incorporated into the indoor unit.

If you wish to install a standard RC-E3 wall remote controller, you must disconnect CnB2 plug and socket or disconnect the wiring to CnB so the infrared receiver input and the RC-E3 input do not cause a communication fault with the system.

The standard RC-E3 wall remote controller is terminated on the terminal block TB2 (X Y) via a non polar 2 core screened cable 0.75mm2.

This is not clearly explained in the installation manual supplied with the indoor unit.

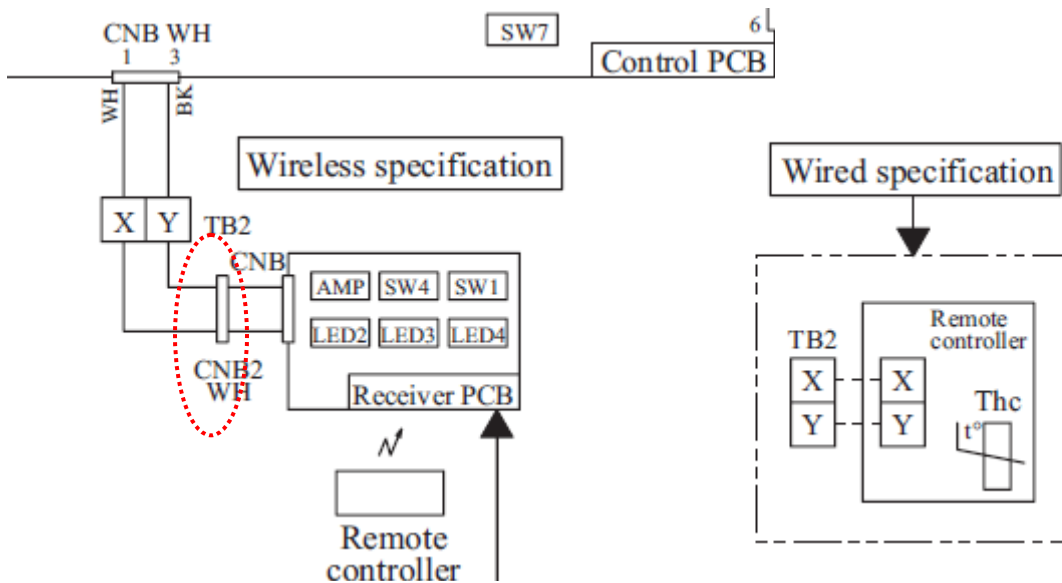

Model	Controller	Instruction
FDEN	RCN-E1R	Factory Setting
FDE	RC-E3	Disconnect Receiver

Regards

Glenn Roulston  
National Sales Manager  
Mitsubishi Heavy Industries Air-Conditioners Australia, Pty. Ltd.

[glenn\\_roulston@mhiaa.mhi.co.jp](mailto:glenn_roulston@mhiaa.mhi.co.jp)