

The installation **GUIDE**

The installation  
**GUIDE**

**FOLLOW**

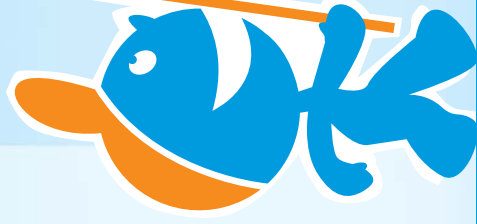

[www.sauermannpumps.com](http://www.sauermannpumps.com)

 **sauermann**<sup>TM</sup>

# CONTENTS

## GENERAL INFORMATION

- Why, how?** p. 4  
2 evacuation options
- What is a condensate removal pump?** p. 5  
Advantages  
Different types: piston, impeller and peristaltic
- Which operating mode?** p. 6  
3 different ways
- Which detection system?** p. 6-7  
3 detection systems



## HOW TO CHOOSE YOUR CONDENSATE REMOVAL PUMP

- Which pump for which system?** p. 8  
Removal pump tables p. 12  
Cooling capacity p. 13  
Actual flow rates
- Technical specifications of the pumps** p. 21



## HOW TO INSTALL YOUR CONDENSATE REMOVAL PUMP



- A few basic rules** p. 22  
DELTA PACK pump with integral detection p. 24  
Piston pumps with remote detection p. 26  
Monoblock impeller pumps with tank p. 29  
Peristaltic pumps p. 32  
Dosing pump p. 36
- Wiring diagrams** p. 37
- Alarm operating examples** p. 40

**ACCESSORIES:  
ESSENTIALS** p. 42

**QUALITY, GUARANTEE,  
SERVICE** p. 41

**NOTES** p. 46



This guide has been produced with the generous support of Messrs. Maurice Perez, Paul Henri Blanc and Jean-Pierre Benoit.

# GENERAL INFORMATION

## WHY, how?

Condensates (drops of water caused by warm, humid air passing over a cold surface) are formed in air conditioning, refrigeration and condensing boiler units.

There are **2 ways** of removing them

### Gravity evacuation

1

Evacuate the condensates by **gravity**, which means dealing with **technical and aesthetic problems** (distant drainage outlet, not enough fall, damage to walls and unsightly pipework).



### The removal pump

2

Or, install a **condensate removal pump** (smaller dimensions, the **appearance of the installation is preserved, simple and quick to install**, safer as equipped with alarm and non return valve).









## WHAT IS a condensate removal pump?

It is a system which consists of a pump unit and a detection unit allowing condensates to be evacuated to a water drainage outlet where there is no gravity fall.

This technology has **3 advantages**:

- 1 It **protects the appearance** of the customer's installation (no unsightly pipework).
- 2 **Easy, simple and safe** to install.
- 3 **Reduction of the risk of bacterial contamination** by waste water (no stagnation or back-flow of water due to non return valves)

There are **3 types** of condensate removal pumps:

	PISTON	IMPELLER	PERISTALTIC
Air conditioning			
Refrigeration			
Heating			

# WHICH operating mode?

Whether monoblock or compound type, condensate removal pumps operate in **3 different ways**:

## ① Reciprocating piston method

These pumps are fitted with a piston which first draws in, then evacuates the condensate.

## ② Centrifugal impeller method

A centrifugal impeller evacuates the condensate. These pumps are intended for high flow rate requirements and are particularly suitable for contaminated condensates

## ③ Peristaltic pumps

A roller compresses a pipe which drives out the condensates (containing contaminants or not). These pumps are self-priming and can operate dry.

# WHICH detection system?

SAUERMANN has developed

## 3 detection systems:

**The first** is based on two mechanical float switches one of which controls the **On/Off** levels and the other the **Alarm**.

→ Fitted on impeller pumps.

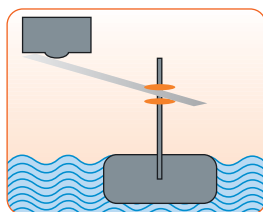

On/Off

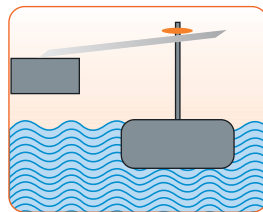

Alarm

## The second

is based on a float switch controlling 3 levels:

1. On,
2. Off,
3. Alarm.

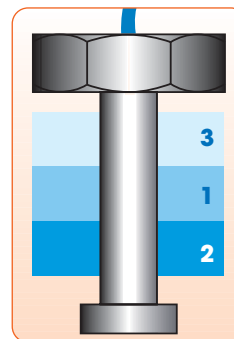

## NEW FEATURE:

The infrared system with 3 detection levels:

- On,
- Off, } lowered by 6 mm.
- Alarm.

It combines 2 level optical detection (ON/OFF) with magnetic detection using a float switch which operates the alarm.

→ Fitted on piston pumps.

As it is largely unaffected by the nature of the condensates (oil or grease on the surface, deposits of scale, dust or algae formation) **float switch detection is very reliable**.

The presence of an alarm level leads to increased safety.

As soon as a problem is detected (abnormally high water level leading to a risk of overflow), the pump **automatically cuts** off the air conditioning system compressor or **triggers an audible or visual alarm**.

Problems may be caused by different reasons:

- power cut
- pump stoppage
- pinched pipe

## The third

operates by detecting a temperature difference across the cooling coil of more than 6°C between two temperature sensors.

→ Fitted on PE 5100 peristaltic pumps.

# HOW TO CHOOSE YOUR CONDENSATE REMOVAL PUMP

## SELECTING pumps

■ Piston pumps for air conditioners up to 10 kW and up to 30 kW

### YOU NEED TO KNOW THE FOLLOWING CHARACTERISTICS:

1 The volume of condensates produced or the refrigerating capacity of your installation will give you an indication of the volume of condensates to be removed.

2 The type of appliance which you are fitting it to.

Choose **your pump** based on these characteristics. Check that the model you choose has a sufficient **flow rate / pressure ratio**.

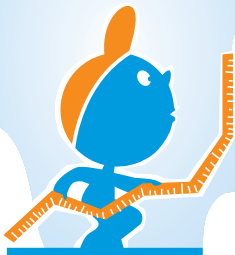

## WHICH PUMP FOR WHICH SYSTEM?



APPLICATIONS	SI 1082 DELTA PACK D: 8 l/h R: 6 m	SI 3080 SI 3080 IR D: 8 l/h A: 1 m R: 6 m	SI 3100 SI 2750 D: 10 l/h A: 2 m R: 6 m	SI 3200 D: 20 l/h A: 2 m R: 6 m	SI 1730 D: 30 l/h A: 2,50 m R: 10 m	EE 1650 D: 30 l/h R: 13 m
AIR CONDITIONING Max cooling capacity	10 kW	10 kW	10 kW	20 kW	30 kW	30 kW
WALL OR FLOOR MOUNTED						
Wall	<b>DELTA</b>					
Consoles						
Fan-coil units						
Air conditioning units						
CEILING MOUNTED						
Ceiling suspended						
Ducted units						
Cassette or multi cassette systems						

D: Flow rate - A: Suction - R: Discharge

# SELECTING pumps

Centrifugal impeller method

Peristaltic pumps



Air conditioning units



Wall-mounted air conditioners



Ceiling suspended DX / Chilled water fan-coil units



Ducted



Refrigerated display cabinets



Condensing boilers

## WHICH PUMP FOR WHICH SYSTEM?

APPLICATIONS	SI 1800 D: 300 l/h R: 4,70 m 	SI 1805 - SI 1820 D: 500 l/h R: 5,40 m 	SI 1822 D: 380 l/h R: 6,20 m 	SI 1850 D: 1100 l/h R: 11 m 	PE 5000 - PE 5100 - PE 5200 D: 6 l/h A: 2 m R: 12 m 	PE 6250 D: 25 l/h A: 2 m R: 10 m 	PE 6000 D: 1,5 l/h A: 2 m R: 15 m 
<b>AIR CONDITIONING</b> Max cooling capacity					8 kW		
<b>WALL OR FLOOR MOUNTED</b>							
Wall							
Consoles							
Fan-coil units							
Air conditioning units							
<b>CEILING MOUNTED</b>							
Ceiling suspended							
Ducted units							
Cassette or multi cassette systems							
Evaporators							
Display cabinets							
Humidifiers/dehumidifiers							
Gas condensing boilers							
<b>AIR COOLING TOWERS</b>							

D: Flow rate - A: Suction - R: Discharge

# Cooling capacity and examples of actual flow rates

## THE REFRIGERATING CAPACITY GIVES YOU THE VOLUME OF CONDENSATES TO BE REMOVED

Use the cooling capacity information supplied by the manufacturer of the air conditioner. It is generally estimated that, for normal usage conditions, the volume of condensates to be removed varies from **0.5 to 0.8 l/hr per kW of cooling capacity**. This value may be doubled in very humid areas.

**For example:** a cooling capacity of 3 kW will produce from 1.5 to 2.4 l/hr of condensates to be removed.

## Installation Overview

For pumps SI 1082, DELTA<sup>1</sup>, SI 3080, SI 3080 IR, SI 3100, SI 3100 IR, SI 3200, SI 3200 IR, SI 2750, SI 1730, PE 5000, PE 5100, PE 5200, PE 6250

You must take into account the head loss connected with:

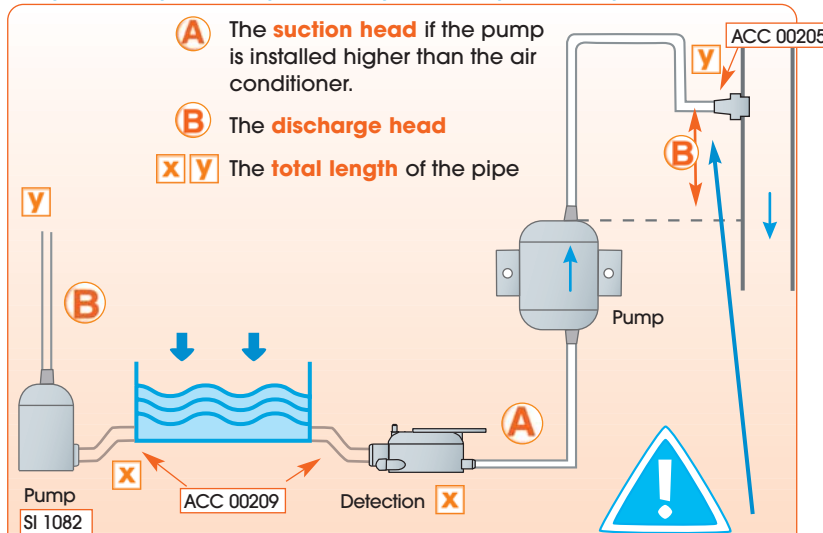

Connections are always made above the level of the pump to prevent a siphon effect in the pipes and the pump becoming unprimed (B>0).

## Actual flow rates for the pumps

SI 1082 - DELTA <sup>1</sup>					
THE HEAD LOSSES DEFINED IN THIS TABLE ARE CALCULATED WITH 1/4" FLEXIBLE PIPEWORK OF 6 MM INTERNAL DIAMETER	DISCHARGE HEAD	TOTAL PIPE LENGTH			
	(B)	(X) (Y) 5 m	10 m	20 m	30 m
	1 m	6.8	6.3	5.3	4.3
	2 m	5.5	5	4.1	3.2
	3 m	4.2	3.8	3	2.5
	4 m	3	2.6	2.2	2
	5 m	2.2	2	1.8	1.5
	6 m	1.5	1.4	1.2	1

SI 3080 - SI 3080 IR					
THE HEAD LOSSES DEFINED IN THIS TABLE ARE CALCULATED WITH 1/4" FLEXIBLE PIPEWORK OF 6 MM INTERNAL DIAMETER	DISCHARGE HEAD	TOTAL PIPE LENGTH			
	(B)	(X) (Y) 5 m	10 m	20 m	30 m
	1 m	6.8	6.3	5.3	4.3
	2 m	5.5	5	4.1	3.2
	3 m	4.2	3.8	3	2.5
	4 m	3	2.6	2.2	2
	5 m	2.2	2	1.8	1.5
	6 m	1.5	1.4	1.2	
SUCTION HEAD	(A)				
0 m					
	1 m	5.6	5.2	4.3	3.4
	2 m	4.3	3.9	3.1	2.3
	3 m	3	2.7	2	1.6
	4 m	1.8	1.5	1.2	1.1
	5 m	1	0.9	0.8	0.6
	6 m	0.3	0.2	0.2	0.1

## Actual flow rates for the pumps

SI 3100 - SI 2750						
THE HEAD LOSSES DEFINED IN THIS TABLE ARE CALCULATED WITH 1/4" FLEXIBLE PIPEWORK OF 6 MM INTERNAL DIAMETER	DISCHARGE HEAD B	TOTAL PIPE LENGTH				
		X	Y			
		5 m	10 m	20 m	30 m	
SUCTION HEAD 0 m A	1 m	9.5	9	8.2	7.4	
	2 m	7	6.5	5.7	4.9	
	3 m	5	4.6	3.9	3.4	
	4 m	4	3.6	3.1	2.8	
	5 m	3.2	2.7	2.5	2.3	
	6 m	2.5	2.2	2	1.8	
MAX SUCTION HEAD 1 m	1 m	7.5	7	6.2	5.4	
	2 m	6	5	4.2	3.4	
	3 m	4.8	3.5	2.9	2.5	
	4 m	3.6	2.6	2.1	1.8	
	5 m	2.2	1.7	1.5	1.3	
	6 m	1.5	1.2	1	0.8	
MAX SUCTION HEAD 2m	1 m	6.2	5.7	4.9	4.1	
	2 m	5	4.5	3.7	2.9	
	3 m	3.8	3.4	2.7	2.2	
	4 m	2.4	2	1.5	1.2	
	5 m	1	0.5	0.3	0	
	6 m	0.5	0	0	0	



## Actual flow rates for the pumps

SI 3200						
THE HEAD LOSSES DEFINED IN THIS TABLE ARE CALCULATED WITH 1/4" FLEXIBLE PIPEWORK OF 6 MM INTERNAL DIAMETER	DISCHARGE HEAD B	TOTAL PIPE LENGTH				
		X	Y			
		5 m	10 m	20 m	30 m	
SUCTION HEAD 0 m A	1 m	19	17.5	15.5	13.5	
	2 m	17.5	16	14	12	
	3 m	16	14	12	10	
	4 m	14	12	10	8.5	
	5 m	11.5	10	8.5	7	
	6 m	9.5	8	7	6	
SUCTION HEAD 1 m	1 m	16.5	15.5	13.5	12	
	2 m	14.5	13.5	11.5	11	
	3 m	12.5	11.5	10.5	10	
	4 m	10	9	8.5	8	
	5 m	8.5	7.5	6.5	5.5	
	6 m	7	5	4	3	
MAX SUCTION HEAD 2 m	1 m	13	12.5	12	11	
	2 m	12	11.5	11	10	
	3 m	11	10.5	10	9	
	4 m	8	7.5	7	6	
	5 m	6	5.5	5	5	
	6 m	4	3.5	3	3	



# Actual flow rates for the pumps

SI 1730					
THE HEAD LOSSES DEFINED IN THIS TABLE ARE CALCULATED WITH 1/4" FLEXIBLE PIPEWORK OF 6 MM INTERNAL DIAMETER	DISCHARGE HEAD	TOTAL PIPE LENGTH			
	(B)	5 m	10 m	20 m	30 m
SUCTION HEAD 0 m (A)	1 m	29	27	25	23
	2 m	27.5	25.5	24	22
	3 m	25.5	24	22	20.5
	4 m	23.5	22	20	19
	5 m	21	19.5	18	16.5
	6 m	18	16.5	15	14
	7 m	15.5	14	12.5	11.5
	8 m	13	11.5	10	9
	9 m	10.5	9	7.5	6.5
	10 m	7.5	6	5	4
SUCTION HEAD 1 m	1 m	24	22	20	20
	2 m	22	21	20	19
	3 m	20	19	18	17.5
	4 m	17	16.5	16	15.5
	5 m	14.5	14	13.5	13.5
	6 m	12	11.5	11	11
	7 m	10.5	10	9.5	9
	8 m	8.5	8	7.5	7
	9 m	6.5	6	5.5	5
	10 m	5	4	3.5	3
MAX SUCTION HEAD 2 m	1 m	20	19	18	17.5
	2 m	17	16.5	16	15.5
	3 m	14.5	14	13.5	13.5
	4 m	12	11.5	11	11
	5 m	10.5	10	9.5	9
	6 m	8.5	8	7.5	7
	7 m	6.5	6	5.5	5
	8 m	5	4	3.5	3
	9 m	2.5	2	1.5	1

# Installation overview

For pumps EE1650, SI1800, SI1805, SI1820, SI1822, SI1850

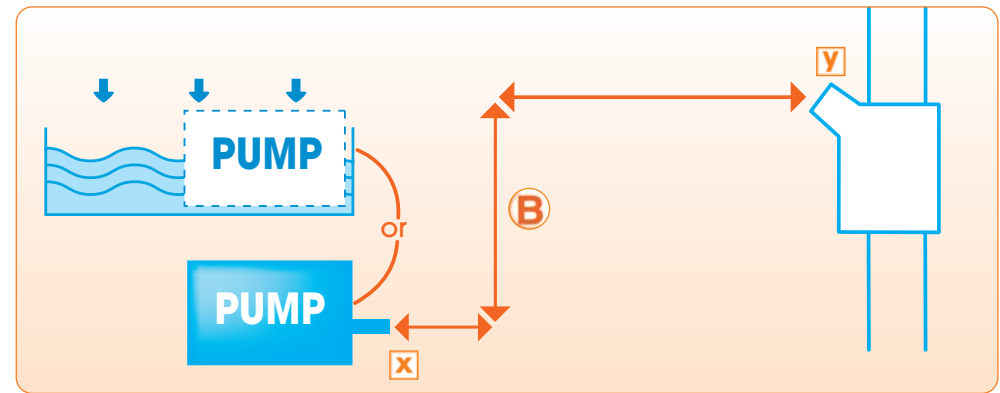

(B) Discharge head

(X) (Y) Total pipe length

# Actual flow rates for the pumps

EE 1650					
THE HEAD LOSSES DEFINED IN THIS TABLE ARE CALCULATED WITH 1/4" FLEXIBLE PIPEWORK OF 6 MM INTERNAL DIAMETER	DISCHARGE HEAD	TOTAL PIPE LENGTH			
	(B)	5 m	10 m	20 m	30 m
	1 m	29	27	25	23
	2 m	27.5	25.5	24	22
	3 m	25.5	24	22	20.5
	4 m	23.5	22	20	19
	5 m	21	19.5	18	16.5
	6 m	18	16.5	15	14
	7 m	15.5	14	12.5	11.5
	8 m	13	11.5	10	9
	9 m	10.5	9	7.5	6.5
	10 m	7.5	6	5	4

# Actual flow rates for the pumps

SI 1800					
THE HEAD LOSSES DEFINED IN THIS TABLE ARE CALCULATED WITH 1/4" FLEXIBLE PIPEWORK OF 10 MM INTERNAL DIAMETER	DISCHARGE	TOTAL PIPE LENGTH			
	HEAD	5 m	10 m	20 m	30 m
	(IN L/H)	(IN L/H)	(IN L/H)	(IN L/H)	(IN L/H)
	1 m	230	180	145	120
	2 m	165	130	100	85
	3 m	100	80	60	50
	4 m	40	30	20	15

SI 1822					
THE HEAD LOSSES DEFINED IN THIS TABLE ARE CALCULATED WITH 1/4" FLEXIBLE PIPEWORK OF 10 MM INTERNAL DIAMETER	DISCHARGE	TOTAL PIPE LENGTH			
	HEAD	5 m	10 m	20 m	30 m
	(IN L/H)	(IN L/H)	(IN L/H)	(IN L/H)	(IN L/H)
	1 m	330	260	220	190
	2 m	275	220	190	160
	3 m	220	175	155	135
	4 m	160	130	120	100
	5 m	100	80	70	60
	6 m	20	15	10	10



SI 1805 - SI 1820					
THE HEAD LOSSES DEFINED IN THIS TABLE ARE CALCULATED WITH 1/4" FLEXIBLE PIPEWORK OF 10 MM INTERNAL DIAMETER	DISCHARGE	TOTAL PIPE LENGTH			
	HEAD	5 m	10 m	20 m	30 m
	(IN L/H)	(IN L/H)	(IN L/H)	(IN L/H)	(IN L/H)
	1 m	460	380	280	200
	2 m	390	320	240	180
	3 m	300	250	190	150
	4 m	200	180	130	100
	5 m	90	80	60	50

SI 1850					
THE HEAD LOSSES DEFINED IN THIS TABLE ARE CALCULATED WITH 1/4" FLEXIBLE PIPEWORK OF 10 MM INTERNAL DIAMETER	DISCHARGE	TOTAL PIPE LENGTH			
	HEAD	5 m	10 m	20 m	30 m
	(IN L/H)	(IN L/H)	(IN L/H)	(IN L/H)	(IN L/H)
	1 m	750	590	375	285
	2 m	675	545	345	270
	3 m	600	500	310	255
	4 m	520	460	285	235
	5 m	450	410	255	215
	6 m		355	225	190
	7 m		300	185	160
	8 m		240	145	125
	9 m		170	100	85
	10 m		85	60	45

## Actual flow rates for the pumps

PE 5000 - PE 5100 - PE 5200							
Flow rate	6 l/h	Max suction head	A	2 m	Max vertical discharge	B	12 m

PE 6000							
Flow rate	1,5 l/h	Max suction head	A	2 m	Max vertical discharge	B	15 m

PE 6250							
Flow rate	25 l/h	Max suction head	A	2 m	Max vertical discharge	B	10 m



## Technical specifications

Pumps	DETECTION LEVELS +/- 2mm			Sound level	Alarm contact at 250V		DIMENSIONS l x w x h in mm		
	On	Off	Alarm				Pump unit	Detection unit	
SI 2750	16	11	19	32 dB(A)	NO/NC	8 A resistive	61 x 38 x 76	55 x 38 x 36	
SI 3080				28 dB(A)	NC	8 A resistive	66 x 44 x 59	55 x 38 x 36	
SI 3100				30 dB(A)	NC	8 A resistive	66 x 44 x 59	55 x 38 x 36	
SI 3200				34 dB(A)	NC	8 A resistive	66 x 44 x 59	55 x 38 x 36	
PE 5200				30 dB(A)	/	/	109 x 110 x 91	55 x 38 x 36	
PE 5000	/	/	/	30 dB(A)	/	/	109 x 110 x 91	/	
PE 5100	/	/	/	30 dB(A)	NC	8 A resistive	109 x 110 x 91	/	
SI 3080 IR SI 3100 IR	10	5	19	28 dB(A)	NC	8 A resistive	66 x 44 x 59	55 x 38 x 36	
SI 1082	18	12	21	28 dB(A)	NC	8 A resistive	66 x 44 x 77	/	
SI 1730	17	11	21	42 dB(A)	NO/NC	8 A resistive	74 x 52 x 95	57 x 40 x 36	
MONOBLOCK PUMPS WITH TANK									
Pumps	On	Off	Alarm	Sound level	Alarm contact at 250V		Pump unit	Detection unit	
EE 1650	Under the tank	16	10	21	52 dB(A)	NC	8 A resistive	160 x 85 x 88	0.5 l
	In the tank	21	15	26	52 dB(A)	NC	8 A resistive	160 x 85 x 88	0.5 l
SI 1800	40	28	66	54 dB(A)	NC	4 A resistive	283 x 127 x 161	2 l	
SI 1805	24	13	30	47 dB(A)	NC	4 A resistive	195 x 130 x 122	0.5 l	
SI 1820	43	27	67	47 dB(A)	NC	4 A resistive	195 x 130 x 170	2 l	
SI 1822	75	20	90	47 dB(A)	NC	4 A resistive	305 x 152 x 235	3.8 l	
SI 1850	70	20	95	66 dB(A)	NC	4 A resistive	305 x 152 x 257	3.8 l	

# HOW TO INSTALL YOUR CONDENSATE REMOVAL PUMP

## A few Basic Rules

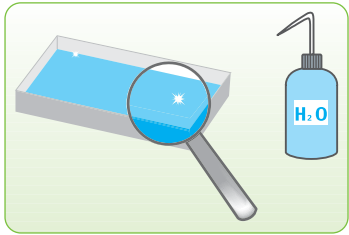

Before installation, thoroughly rinse the coil and the condensates collection tank to remove any foreign bodies and metal particles.

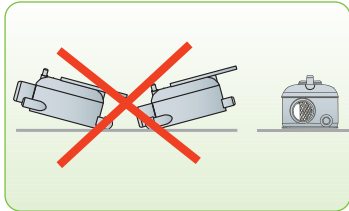

When the pump has a separate detection unit, it must be fixed horizontally on a support.

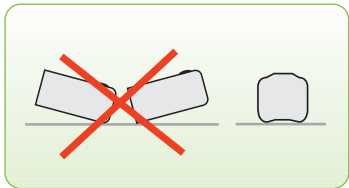

Monoblock tank pumps must always be fitted horizontally on a support.

Failure to observe these rules can lead to poor results (tank overflow, high noise level, abnormal overheating etc.) which are both inconvenient for the end user and costly for the installer.

**YOU ARE STRONGLY ADVISED TO AVOID THE USE OF DETERGENT OR AGGRESSIVE PRODUCTS WHEN CLEANING THE TANK OF MONOBLOCK PUMPS**



**IMPORTANT NOTE ON COMMISSIONING PUMPS WITH REMOTE DETECTION**

Before carrying out any operation on the pump, make sure the installation is disconnected from the power supply.



To ensure that the pumps function correctly in the future, ensure that when you first commission them (and after each maintenance operation) the pumps are properly primed.

Check that the suction pipe (between the detection unit and the pump) and part of the discharge pipe are filled with water.



You can use the priming squeeze bottle **ACC 00401**.

# Piston pump with integral detection

**DELTA**  
PACK  
**READY TO FIT**

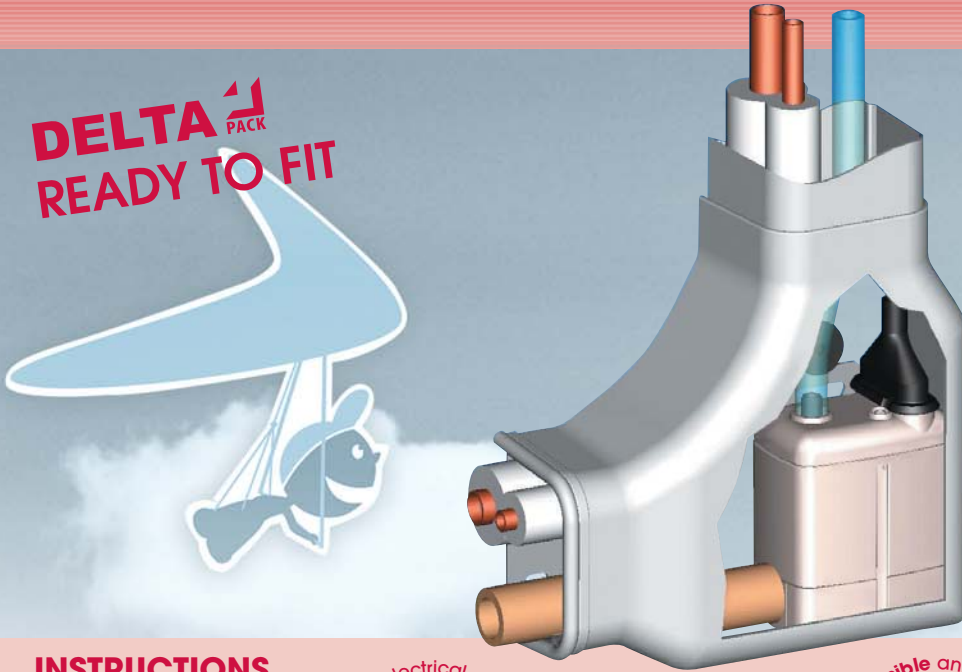

## INSTRUCTIONS

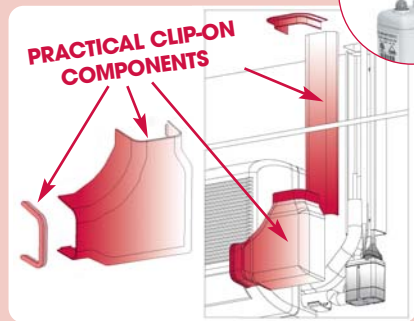

Clip-on pipe, elbow and ceiling duct

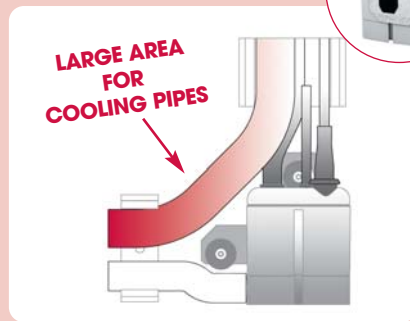

Can be used for routing cooling pipes up to diameter 5/8" - 3/8"



## RECOMMENDED ACCESSORIES

	<b>ACC 00105 / ACC 00150 / ACC 00151</b>
	Clear tubing 6 mm
	ACC 00105: 5m in blister pack
	ACC 00150: in 50m roll ACC 00151: reinforced, 50m roll

	<b>ACC 00205</b>
	6 self-sealing fitting for condensate removal.

# Piston pump with integral detection

**DELTA**  
PACK Ready to fit assembly for wall-mounted air conditioners up to 10 kW

## Delta pack comprises:

- a mini pump with integral detection SI 1082
- a complete assembly kit containing:
  - a clip-on cover,
  - 75 cm of 70 x 55 mm duct,
  - all assembly accessories.

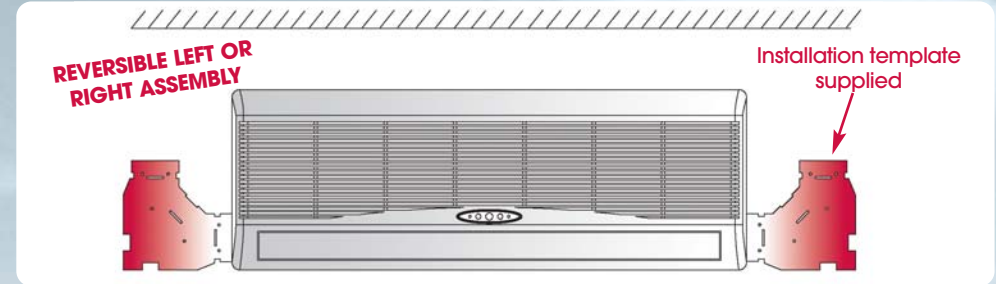

Allows the pump to be assembled on the left or right of the air conditioner.

## INSTALLATION SI 1082

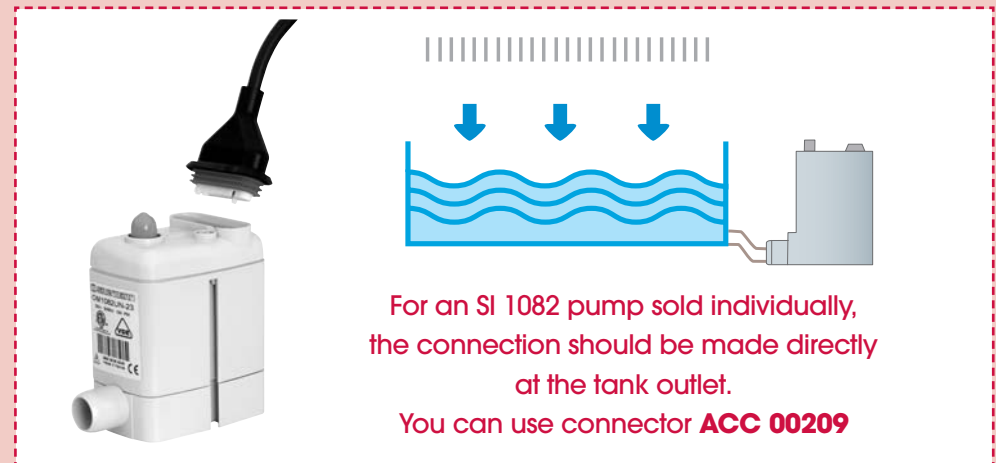

Carry out an in situ test and prime the pump. To do this, gently fill with water using the priming squeeze bottle (**ACC 00401**).

## Piston pumps with remote detection

SI 3080 IR/SI 3080/SI 3100 IR/SI 3100/SI 3200/SI 3200 IR/SI 2750/SI 1730



**SILENT**

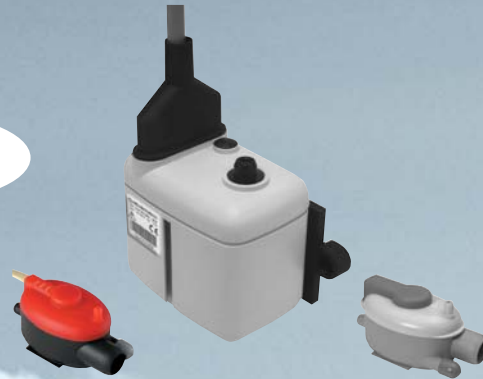

SI 3080 IR, SI 3080, SI 3100 IR, SI 3100 up to 10 kW /  
SI 3200 IR, SI 3200 up to 20 kW

## Piston pumps with remote detection

SI 3080 IR/SI 3080/SI 3100 IR/SI 3100/SI 3200/SI 3200 IR/SI 2750/SI 1730



SI 2750  
up to 10 kW



SI 1730  
up to 30 kW



### DETECTION UNIT INSTALLATION

The vent pipe allows the air to be bled from the detection unit. You are advised to use the 4 mm clear tube supplied. Its length allows the upper level of the tube to be slightly above the maximum level of the condensates drain tank. In the event of a fault, this avoids overspill (principle of communicating vessels). When commissioning, ensure that this breather tube does not contain any water.

**Do not use a longer tube than the one supplied.**

The detection unit can be **connected in 3 ways:**

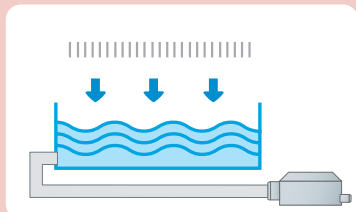

At the outlet of the condensate evacuation tube

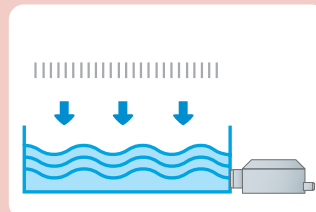

At the tank outlet

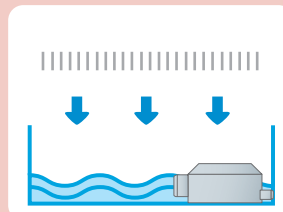

Directly inside the tank

The detection unit can be **connected** either at the **front** or the **rear**.

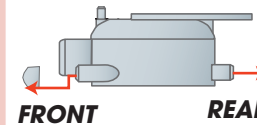

\*Supplied as standard: outlet at back. Blank the unused outlet with the plug supplied.



**Clean the filter** every time the air conditioner is serviced for detectors which have these (SI 1730)

### Assembly position of the detection unit

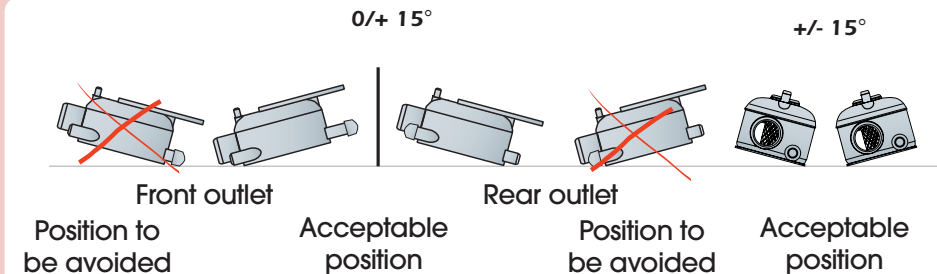

# Piston pumps with remote detection

SI 3080 IR/SI 3080/SI 3100 IR/SI 3100/SI 3200/SI 3200 IR/SI 2750/SI 1730



**SILENT**

AIR  
CONDITIONING



Carry out an in situ test and prime the pump. To do this, gently fill with water using the priming squeeze bottle (ACC 00401).

# Monoblock pump with tank

EE 1650 Monoblock pump with integrated tank for air conditioners up to 30 kW



**POWERFUL**

AIR  
CONDITIONING



EE 1650  
up to 30 kW  
tank: 0.5 l

## PUMP UNIT INSTALLATION

The recommended fitting positions for the pump are: (avoid all other positions)

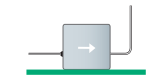

Acceptable position



Recommended position

Vertical discharge guarantees that the non return valve is watertight. The electrical connection must always be above the water inlet/outlet.

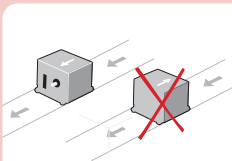

Ensure that the condensates pass through the pump in the correct direction (see arrow on unit)

## RECOMMENDED ACCESSORIES



ACC 00105 / ACC 00150 / ACC 00151

Clear tubing 6 mm  
ACC 00105: 5m in blister pack  
ACC 00150: in 50m roll  
ACC 00151: reinforced, 50m roll



The pump must not be splashed nor located in a damp environment.

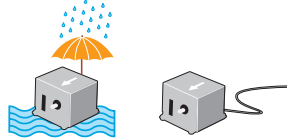

Water may accumulate from condensation in the tube or due to a leak from the clear tube/pump end piece connection.



ACC 00205

6 self-sealing fittings for condensate removal.



ACC 17010

In-line filter for SI 1730.

## INSTALLATION

The pump can be connected in 2 ways:

the pump collects the condensates via the gravity inlet (in the top)

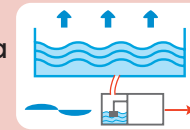

The pump is placed directly in the condensate collecting tank

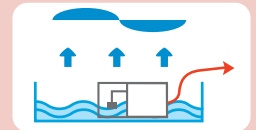

To use an EE 1650 in a condensate collecting tank, where the condensates are fed from below, follow the procedure outlined below.

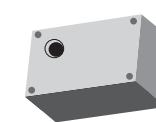
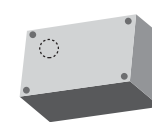
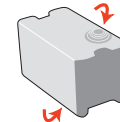

**CAUTION**  
irreversible procedure

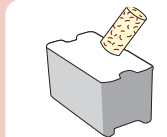

Clean the filter every time the air conditioner is inspected

## RECOMMENDED ACCESSORIES



ACC 00205

6 self-sealing fittings for condensate removal.



ACC 00105/ACC 00150/ACC 00151

ACC 00105: 5 m in blister pack  
ACC 00150: in 50 m roll  
ACC 00151: reinforced, 50m roll

# Monoblock impeller pumps with tank

SI 1800 / SI 1805 / SI 1820 / SI 1822 / SI 1850

# Monoblock impeller pumps with tank

SI 1800 / SI 1805 / SI 1820 / SI 1822 / SI 1850



**DYNAMIC**

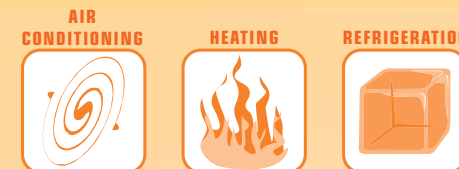

## INSTALLATION

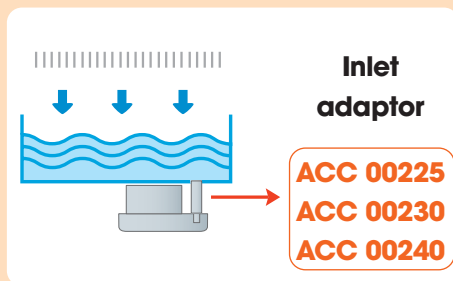
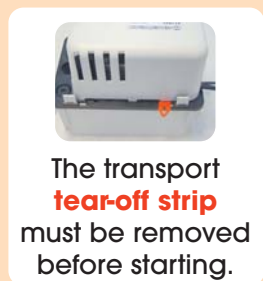

The pump collects the condensates via the inlet **in the top**.

## MAINTENANCE



The inside of the pump must be **regularly cleaned**. For this we recommend that you use a solution containing 5% bleach. Ensure that the float switches remain clean.

## REMOVING THE VALVE



## MECHANICAL ASSEMBLY

All monoblock impeller pumps have a **reversible tank**.

Condensate inlet **on left**



Condensate inlet **on right**



## RECOMMENDED ACCESSORIES

<p><b>ACC 00110</b> Installation kit: 1 x ACC 00225, 1 x ACC 00230, 1 x ACC 00240.</p>	<p><b>ACC 00810</b> for SI 1805, SI 1820 Non return valve Ø 10 mm</p>	<p><b>ACC 00601</b> Control switch. Used to control an additional alarm.</p>
<p><b>ACC 00125 / ACC 00126</b> Clear tubing Ø 10 mm, length 25 m ACC 00125: non-reinforced tube ACC 00126: reinforced tube</p>		<p><b>ACC 00225/ACC 00230/ACC 00240</b> Condensate inlet adapters ACC 00225: 1", Ø 32 mm ACC 00230: 1" 1/4, Ø 32 mm ACC 00240: 1" 1/2, Ø 40 mm</p>

# Peristaltic pumps

PE 5000 / PE 5100 / PE 5200 / PE 6250

PRACTICAL



PE 5000

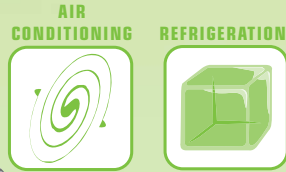

There are 3 different models and therefore **3 possible installations:**

PE 5000

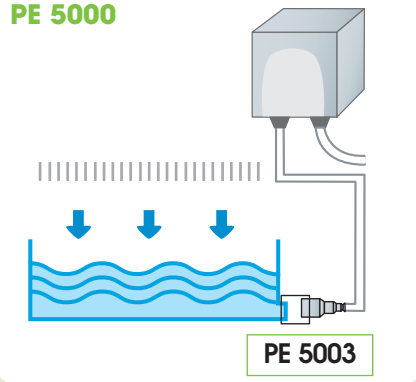

## INSTALLATION PE 5000

Condensates are removed from the air conditioning unit **at the tank outlet** via a 6 x 9 mm tube and the **PE 5003** connector supplied with the pump.

## OPERATION

Pump operation is dependent on the operation of the air conditioning compressor or whenever the system provides cooling. The pump will continue to run for three minutes after the compressor has stopped.

# Peristaltic pumps

PE 5000 / PE 5100 / PE 5200 / PE 6250



## PE 5100

Temperature sensor for the evaporator

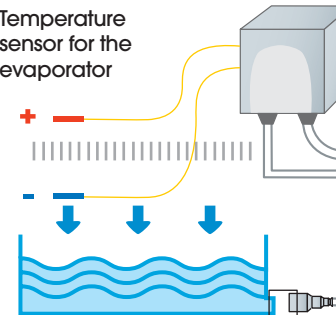

PE 5003



PE 5100



## INSTALLATION PE 5100

Condensates are removed from the air conditioning unit **at the tank outlet** via a 6 x 9 mm tube and the **PE 5003** connector supplied with the pump.

## OPERATION

The pump switches on when the temperature difference across the coil as measured by the two sensors is more than 6°C. The pump stops 3 minutes after the temperature difference falls below 6°C.

Installation example for PE 5000 and PE 5100 pumps

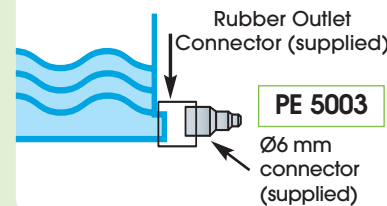

Replacement head PE 5001



Replacement head available for peristaltic pumps PE 5000 / PE 5100 / PE 5200

# Peristaltic pumps

PE 5000 / PE 5100 / PE 5200 / PE 6250



PRACTICAL



PE 5200



# Peristaltic pumps

PE 5000 / PE 5100 / PE 5200 / PE 6250



PE 6250  
Ø 10 mm tube



## PE 5200

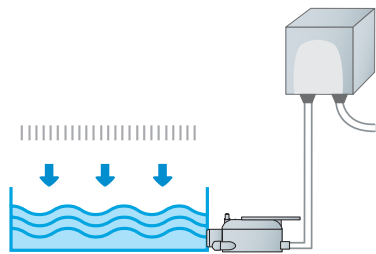

## INSTALLATION PE 5200

The detection unit is connected to the condensate evacuation **tube outlet** or directly **to the tank outlet**. The pump is connected to the detection unit by a 6 x 9 mm tube.

## OPERATION

The pump operates when condensates enter the detection unit. In this configuration, a 230 V / 8 A NC alarm contact is available.

## MAINTENANCE PE 5000/ PE 5100 PE 5200

Replace the tube (PE 5002) at least every year and the pump head (PE 5001) every two years or as required. (Remove the 4 screws, disconnect the connector and fit the new head).



Carry out an in situ test and prime the pump. To do this, gently fill with water using the priming squeeze bottle (ACC00401). Press the test button on the PE 5000 & PE 5100 to operate the pump for three minutes.

Very heavily contaminated condensates can be evacuated with this high flow rate pump and its 10 mm evacuation pipe.

The accessory supplied (**ACC 00601**), to be secured in the condensate tank, switches the pump on and off. It can also be used as an alarm contact in the event of a tank overflow.

## RECOMMENDED ACCESSORIES for PE 6250

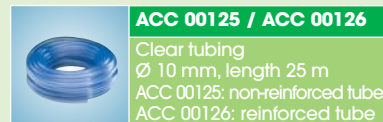

### ACC 00125 / ACC 00126

Clear tubing  
Ø 10 mm, length 25 m  
ACC 00125: non-reinforced tube  
ACC 00126: reinforced tube

## ACCESSORY SUPPLIED for PE 6250



### ACC 00601

Float control switch. Used to control the pump or an alarm.

## RECOMMENDED ACCESSORIES for all peristaltic pumps

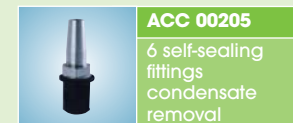

### ACC 00205

6 self-sealing fittings  
condensate removal

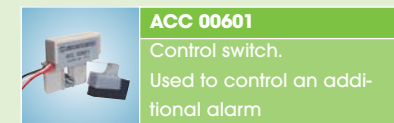

### ACC 00601

Control switch.  
Used to control an additional alarm

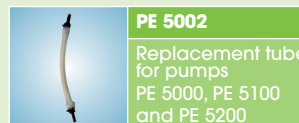

### PE 5002

Replacement tube for pumps  
PE 5000, PE 5100  
and PE 5200



### PE 5001

Replacement head for pumps  
PE 5000, PE 5100  
and PE 5200

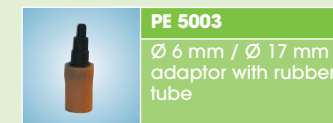

### PE 5003

Ø 6 mm / Ø 17 mm  
adaptor with rubber tube

# DOSING peristaltic pump

PE 6000



PE 6000



## EFFECTIVE AND PREVENTATIVE

Injecting disinfectant and anti-bacterial products\* can sanitise air cooling towers and prevent the transmission of bacteria (Legionnaire's disease) and the formation of algae.

(\*products not supplied, usage frequency, concentration and dosage in accordance with product manufacturers' recommendations).

## PROGRAMMABLE

- In 15 minute intervals on a front-mounted time clock.
- Timer-controlled programmable injection duration of 2 - 18 minutes.

## ACCESSORIES SUPPLIED

### Accessory supplied

Ø 4 mm suction tube (length 3m)

### Accessory supplied

Ø 4 mm discharge tube (length 3m)



### Accessory supplied

Suction strainer



### Accessory supplied

Injection connector with valve

# Wiring DIAGRAM for pumps SI 1082, DELTA PACK, SI 3080 IR, SI 3080, SI 3100, SI 3200, EE 1650, SI 1730

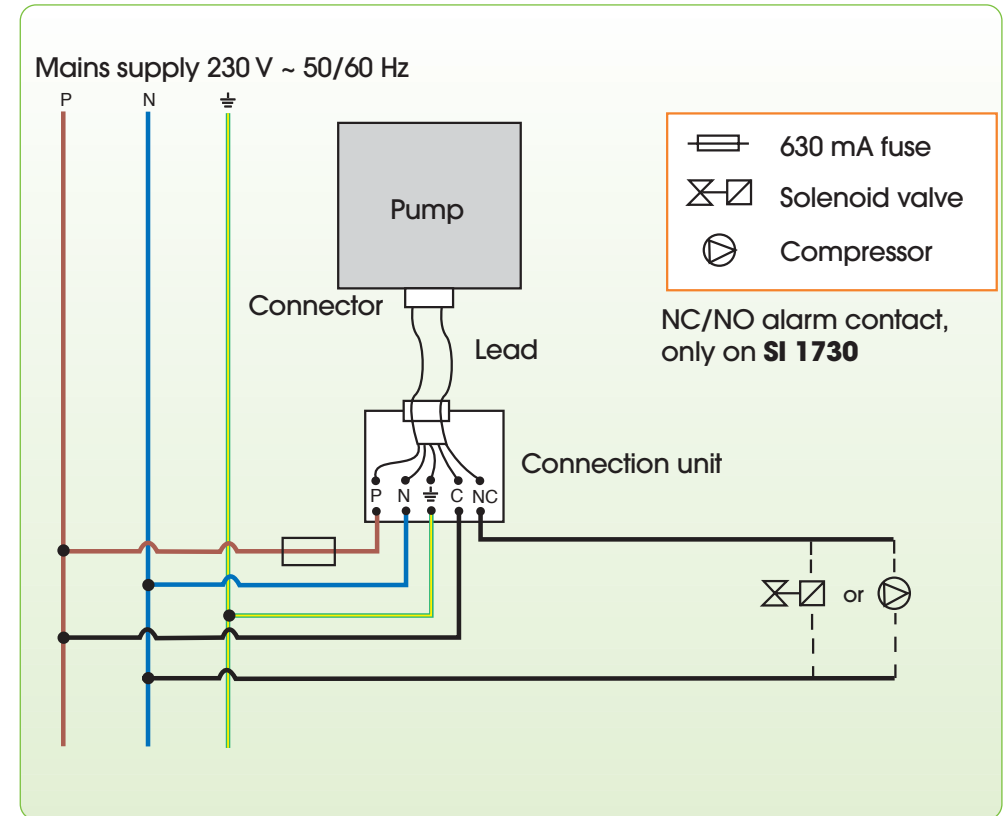

# Wiring DIAGRAM for pumps SI 2750

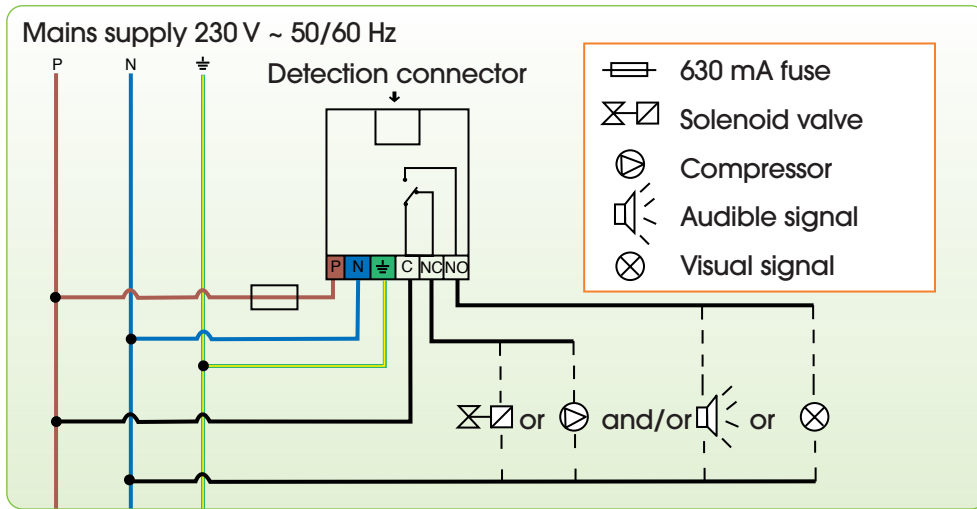

# Wiring DIAGRAM for pumps PE 5000, PE 5100 AND PE 5200

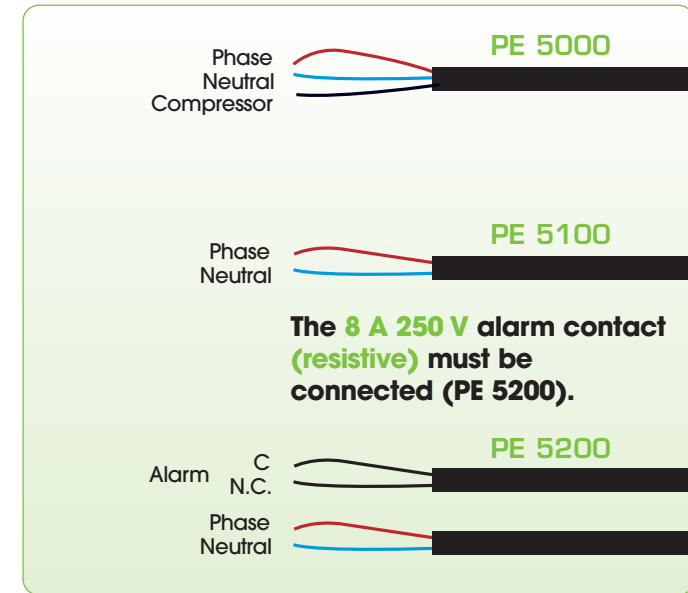

# Wiring DIAGRAM for pumps SI 1800, SI 1805, SI 1820, SI 1822, SI 1850

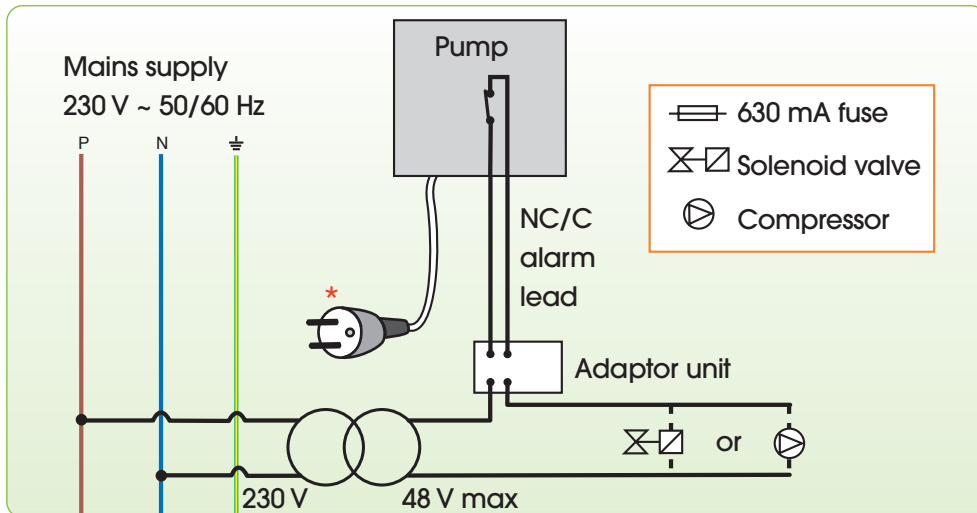

\* plug not supplied on SI 1800, SI 1822 and SI 1850



## IMPORTANT

The pumps must have a power supply that is independent to that of the air conditioner to ensure that they continue to operate if the refrigerating appliance breaks down.

# Alarm operating

## EXAMPLES

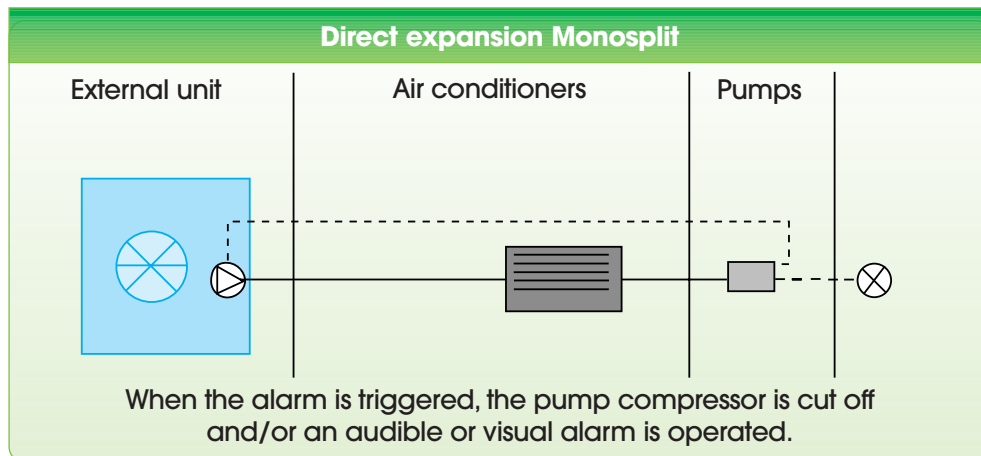
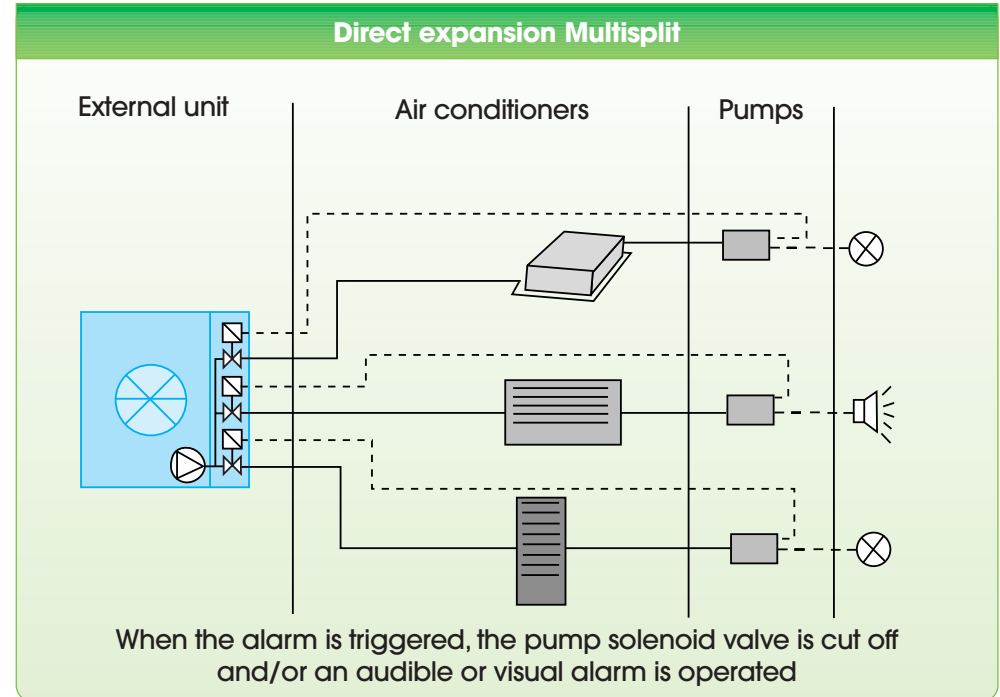
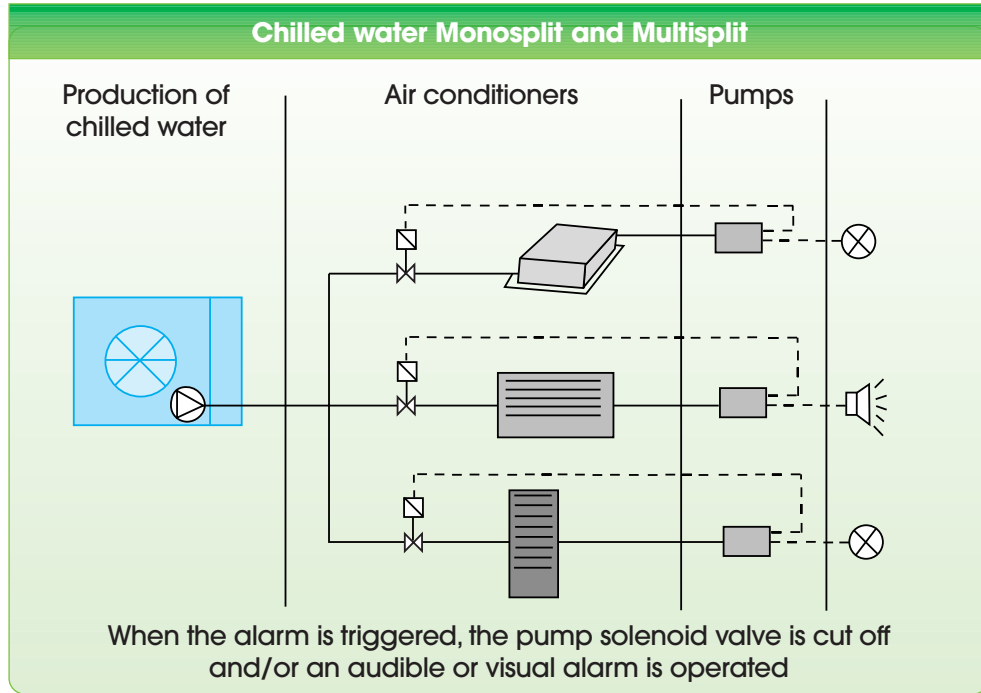

# ACCESSORIES\*: ESSENTIALS



 Piston pumps for air conditioners up to 10 kW and up to 30 kW

 Centrifugal impeller method

 Peristaltic pumps

	<b>ACC 00100</b>	Installation kit SI 2750
	<b>ACC 00105</b> <b>ACC 00150</b> <b>ACC 00151</b>	ACC 00105: 5m in blister pack ACC 00150: in 50m roll ACC 00151: reinforced, 50m roll
	<b>ACC 00106</b>	Blond rubber 50 cm for DELTA PACK, SI 2750 / SI 3080 IR / SI 3080 / SI 3100 / SI 3200 / SI 1730
	<b>ACC 00110</b>	Installation kit comprising the following components: 1 X ACC 00225, 1 X ACC 00230, 1 X ACC 00240.
	<b>ACC 00125</b> <b>ACC 00126</b>	Clear tube, 10 mm int. On 25 m coil ACC 00125: non-reinforced tube ACC 00126: reinforced tube
	<b>ACC 00201</b>	Ø 17 / Ø 22 mm adaptor kit
	<b>ACC 00202</b>	Ø 17 / Ø 32 mm adaptor kit
	<b>ACC 00203</b>	Ø 17 / Ø 32 mm reduction for reducing flow
	<b>ACC 00204</b>	5 Ø 6 mm straight connectors + 5 Ø 6 mm elbow connectors.
	<b>ACC 00205</b>	6 condensate self-sealing evacuation connectors.
	<b>ACC 00208</b>	90° elbow, 15 x 15 mm

\* Accessories are only guaranteed for the applications for which they are recommended.

	<b>ACC 00209</b>	15 x 15 mm flexible connector used to drain the tank completely.
	<b>ACC 00210</b>	90° elbow, 17 x 15 mm
	<b>ACC 00211</b>	Ø 6 mm Tee connector
	<b>ACC 00225</b> <b>ACC 00230</b> <b>ACC 00240</b>	Condensate inlet adaptors.
	<b>ACC 00401</b>	Squeeze bottle: used to test the pump without removing the unit.
	<b>ACC 00501</b>	10 double-sided stickers.
	<b>ACC 00601</b>	Float control switch. Used to control the pump or an alarm SI 1800 / SI 1805 / SI 1820 / SI 1822 / SI 1850 / PE 5000 / PE 5100 / PE 6250.
	<b>ACC 00703</b>	3 m extension for SI 2750 / SI 3080 IR/ SI 3080 SI 3100 / SI 3200 / SI 1730 / PE 5200.
	<b>ACC 00705</b>	5 m extension for SI 2750 / SI 3080 IR / SI 3080 SI 3100 / SI 3100 / SI 3200 / SI 1730 / PE 5200.
	<b>ACC 00801</b>	10 mm non return valves for SI 1805 / SI 1820.
	<b>ACC 00805</b>	5 non return valves for Ø 6 mm tube.
	<b>ACC 17010</b>	In-line filter for SI 1730.
	<b>PE 5001</b>	Replacement head For pumps PE 5000 / PE 5100 / PE 5200
	<b>PE 5002</b>	Replacement tube For pumps PE 5000 / PE 5100 / PE 5200
	<b>PE 5003</b>	Ø 17 mm - Ø 6 mm reduction for pumps PE 5000 / PE 5100 / PE 5200

# QUALITY, GUARANTEE, SERVICE

## Our priorities

To anticipate your requirements, meet your expectations in full and provide total satisfaction:

In 1997, Sauermann committed itself to implementing a quality policy in accordance with standard ISO 9002.

In 2003, Sauermann applied to obtain standard ISO 9001 version 2000 and was successful in obtaining it.

Through regular internal audits, standard ISO 9001 version 2000 shows the total involvement at all levels of the company to ensure we constantly work towards:

- Complying with our lead-times
- Controlling our products
- And improving our services.

Our quality requirement continues through developing our products which are subject to certification with the main independent laboratories, in order to obtain the CE, VDE and ETL labels.



## At your service

In practice, our quality policy continues in day to day life through the implementation of customer services:

- **Technical assistance** which, with just one phone call, can provide you with advice and offer the best **tips and information**.
- **Products guaranteed for 24 months**.
- **An effective after sales department.**  
(Products returned to the after sales department are analysed, thus helping to improve our products on a permanent basis).





**FRANCE**

Parc d'activités de l'Orée de Chevry  
Route de Férolles  
77173 CHEVRY-COSSIGNY  
Tel.: (+33) 01 60 62 06 06  
Fax: (+33) 01 60 62 09 09  
E-mail: info@sauermann.fr

**SAUERMANN ITALIA S. R. L.**

Via G.Golini 61/11  
40024 Castel S.Pietro Terme (Bologna) - Italy  
Tél.: (+39)-051-6951033  
Fax: (+39)-051-942254  
E-mail: info@sauermann.it

**SAUERMANN GmbH**

Kernerstrasse 18  
D-74223 FLEIN  
Fon: (+49) 07131/399990  
Fax: (+49) 07131/399992  
E-mail: Sauer mann-Flein@t-online.de

**PENÍNSULA IBÉRICA**

Avda, del Encinar, 1  
Urb. Fuente del Fresno  
28708 SAN SEBASTIAN DE LOS REYES  
(Madrid) ESPANA  
Tel.: (+34) 91 623 64 42  
Fax: (+34) 91 623 64 34  
E-mail: busslinger@telefonica.net

**SAUERMANN UK ltd**

P.O BOX 187 - Lytham St Annes  
FY8 4WN - UK  
Tel.: (+44) 0 870 950 6378  
Fax: (+44) 0 870 950 6379  
Email: sales@sauermann-uk.com

**SAUERMANN N.A. Corp**

300 Vanderbilt Motor Parkway  
Suite 200  
Hauppauge, NY 11788  
Tel: 631-439-6845  
Fax: 631-439-6837

**SAUERMANN SHANGHAI Co. Ltd**

155 Zhangpu Road  
JuYuan Development Park - JiaDing District  
Shanghai 200182 - P.R. CHINA  
Tel.: (+ 86) 21 691 689 61  
Fax: (+ 86) 21 691 689 62  
www.sauermann.com.cn

**SCANDINAVIA, BALTICS, RUSSIA**

Parkgade 8  
6440 AUGUSTENBORG - DENMARK  
Tel.: (+45) 74 47 10 78  
Mobil: (+45) 40 59 10 78  
E-mail: peter.remontius@get2net.dk