



OPERATING & MAINTENANCE INSTRUCTIONS RC-C SERIES AIR COOLED CONDENSERS

MODELS: RC09C-RC25C (Single Phase, 350mm Dia. Fan Motors.)
RC19C-RC115C (Three Phase, 500mm Dia. Fan Motors.)

CONTENTS

- | | |
|------------------------------|---------------------------------|
| 1. Important Recommendations | 5. Electrical Connections |
| 2. Safety Recommendations | 6. Commissioning Instructions |
| 3. Application Ranges | 7. Maintenance Instructions |
| 4. Installation Guide | 8. Decommissioning Instructions |

1. IMPORTANT RECOMMENDATIONS

RC-C air cooled condensers are intended for installation only by **Qualified Refrigeration Personnel** and are to be installed in accordance with the guidelines mentioned in this manual.

(All electrical work is to be carried out by **Qualified Electrical Personnel** and to be in accordance with local electrical regulations.)

2. SAFETY RECOMMENDATIONS

- Condensers are supplied with a **Nitrogen Holding Charge**. (**Release pressure fully before accessing the connection points**.)
- Electrical power to be **isolated** prior to the commencement of any electrical work.
- During normal operation, **pressurized refrigerant** is contained within the condenser. Extreme care should be taken to avoid leakage, as personal injury may occur. (**Avoid the use of sharp objects in close proximity to refrigeration piping**.)
- Extensive gas loss in enclosed area may result in asphyxiation.
- Contact with refrigerant may cause personal injury. (Freeze Burns.)
- Normal operating conditions involve **hot** surfaces within the condenser. Extreme care should be taken to avoid contact.
- Avoid contact with condenser fins, as sharp edges may cause personal injury.
- Insertion of any object into the condenser fans is to be avoided, as this may result in personal injury and/ or equipment damage.
- Operating sound pressure levels may cause discomfort. Refer to catalogue for calculated sound levels.

3. APPLICATION RANGES

- These condensers are intended for the use in Commercial Refrigeration and Air Conditioning systems, with a maximum operating ambient temperature of approximately 60°C. (**Special designs available on application**.)
- Recommended refrigerants: **HFCs, HCFCs**. (Also suitable for CFCs.)
- This series condenser **is not suitable** for use with NH₃. (Ammonia.)
- Standard Condensers are not to be installed in hazardous/combustible environments. (**Special design available on application**.)

4. INSTALLATION GUIDE

The RC-C Series of Air Cooled Condensers are suitable for both **Vertical and Horizontal** air flow.

A. MOUNTING – VERTICAL AIR FLOW

- Remove the condenser from its crate.
- Each condenser is fitted with four legs and four transport brackets as shown in **Figure 1**, all of which need to be removed. The transport brackets can be discarded.
- Using an appropriate lifting device to raise the condenser, the legs can be inverted and re-bolted using the existing leg mounting bolts as shown in **Figure 2**.
- Place the condenser into the installation location and secure using the mounting hole located in the foot of each leg.

PLEASE NOTE:

Minimum diameter of fixing bolts to be 9.525mm. (3/8")

The use of lifting devices during installation is recommended where applicable.

Observe recommended condenser mounting locations as shown in Figure 4.

- Ensure the condenser is installed level, to avoid liquid locking within the coil.
- Refrigeration piping connections should be carried out in accordance with the current "Refrigeration Code of Good Practice" *. (Beware of **HOT** surfaces present during the welding procedure.)
- Refer to **Figure 2** for refrigeration piping connection points.

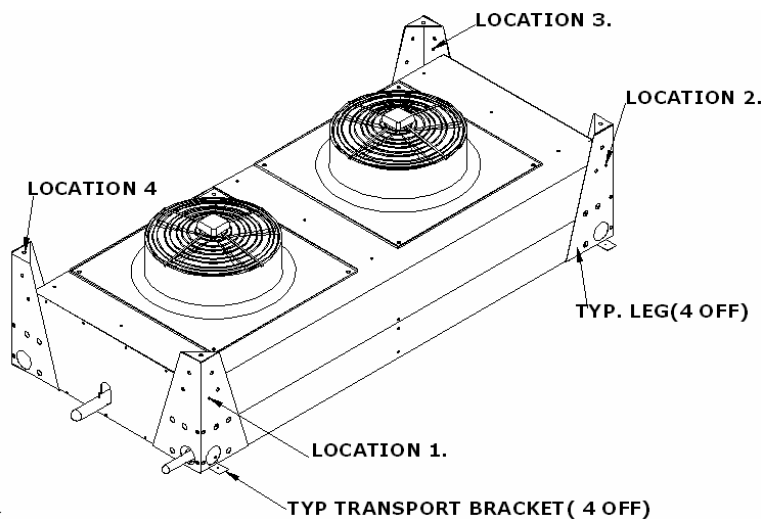

Figure: 1.

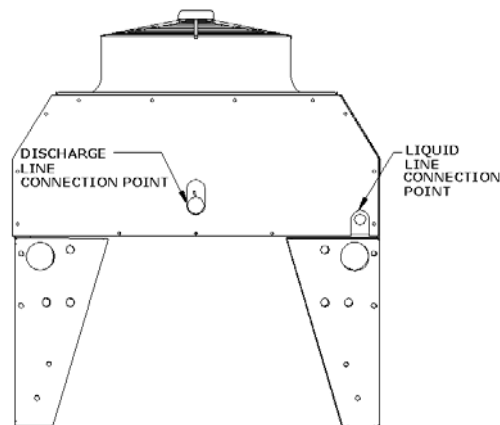

Figure: 2.

B. MOUNTING – HORIZONTAL AIR FLOW

- Remove the condenser from its crate.
- Each condenser is fitted with four legs and four transport brackets as shown in **Figure 1**. Remove transport brackets in locations 1 and 2, refer **Figure 1**, and replace the existing leg mounting bolts. The legs and transport brackets in locations 3 and 4 can be removed and discarded. Please ensure the fixing bolts are refitted to the condenser.
- Place the condenser into the installation location and secure using the mounting holes located in each foot.

PLEASE NOTE:

Minimum diameter of fixing bolts to be 9.525mm. (3/8")

The use of lifting devices during installation is recommended where applicable.

Observe recommended condenser mounting locations as shown in Figure 5.

- Ensure the condenser is installed level, to avoid liquid locking within the coil.
- Refrigeration piping connections should be carried out in accordance with the current "Refrigeration Code of Good Practice" *. (Beware of **HOT** surfaces present during the welding procedure.)
- Refer to **Figure 3** for refrigeration piping connection points.

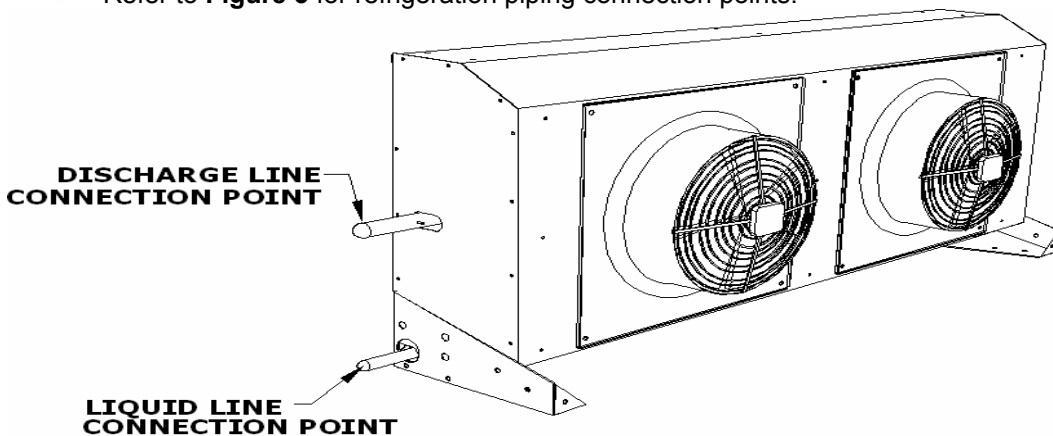

Figure: 3.

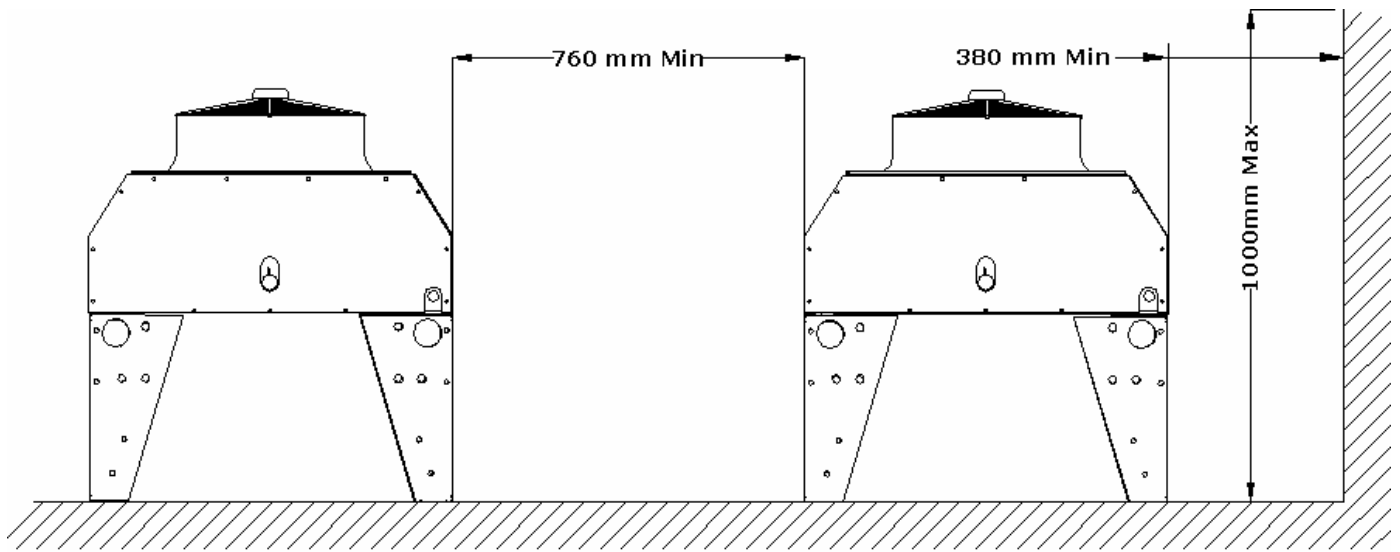

Figure: 4.

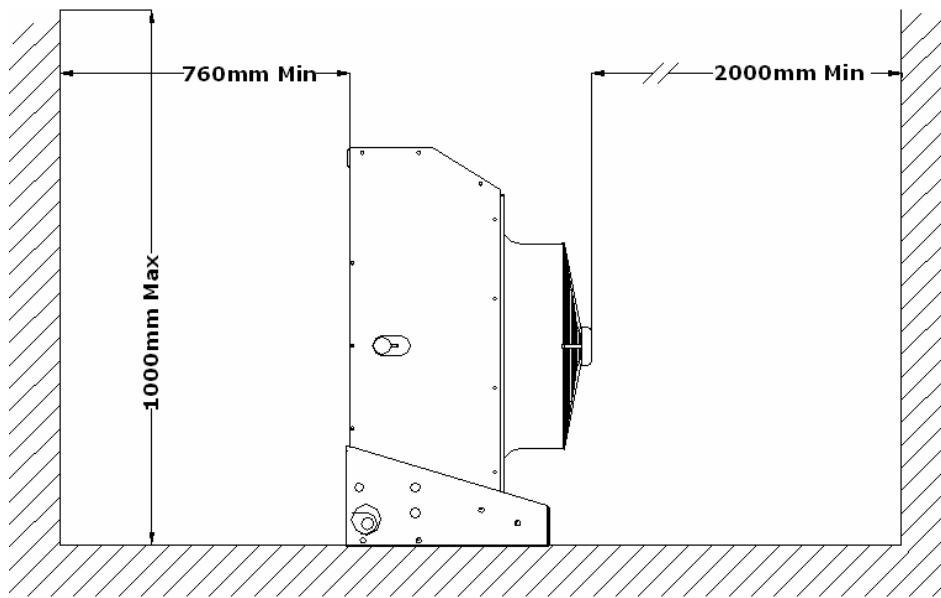

Figure: 5.

5. ELECTRICAL CONNECTIONS

A. FOR MODELS RC09C TO RC25C.

- Fan motors are suitable for 230 Volt $\pm 10\%$, 50 Hz operation only, and are supplied pre-wired to a terminal strip located within a junction box on each individual fan motor. (No common electrical junction box.)
- These motors are to be wired in accordance with **Figure 6**. (Wiring diagram R55 000 035.)

B. FOR MODELS RC19C TO RC115C.

- Fan motors are suitable for 400 Volt $\pm 10\%$, 50 Hz operation only, and are supplied pre-wired to a terminal strip located within a junction box on each individual fan motor. (**230 Volt $\pm 10\%$, 50 Hz Single Phase motors are optional.**) (No common electrical junction box.)
- These motors are to be wired in accordance with **Figure 7**. (Wiring diagram R55 000 004.)

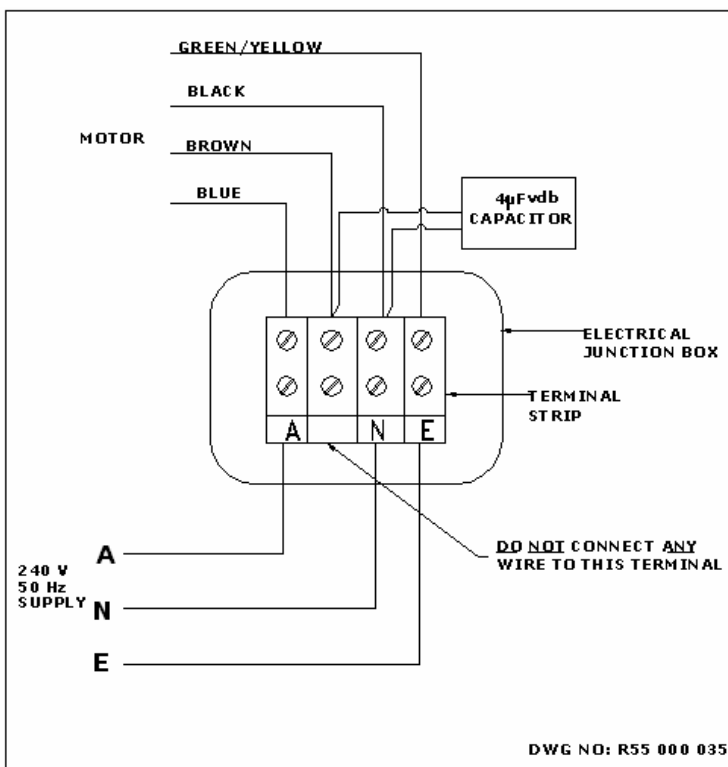

Figure 6.

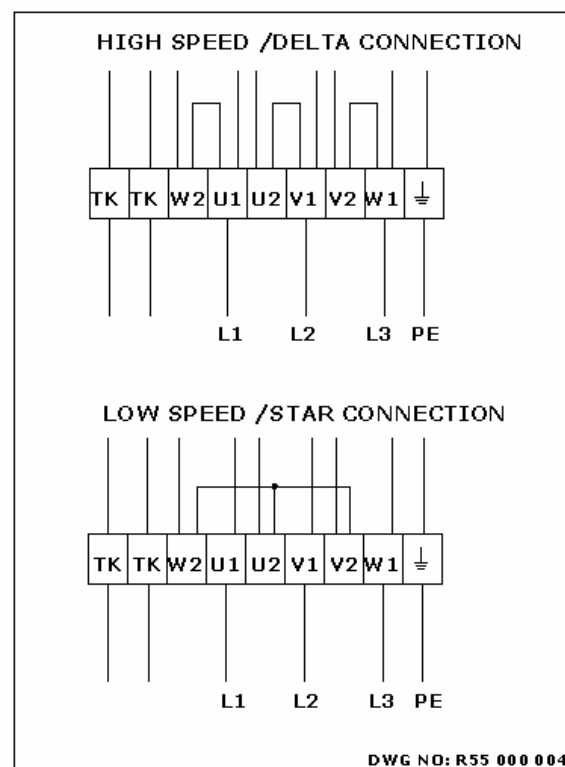

Figure 7.

6. COMMISSIONING INSTRUCTIONS

- Leak testing should be carried out in accordance with the current “Refrigeration Code of Good Practice”*.
- Following leak testing, the system should be evacuated using accepted refrigeration practices. The vacuum pump should be connected to both the high and low pressure sides of the system with all shut-off valves open.
- Refrigerant charging should be carried out in accordance with the current “Refrigeration Code of Good Practice”*.
- **Extreme** care should be taken to avoid direct contact with liquid refrigerant. (Freeze Burns.)
- Ensure the electrical wiring is in accordance with local electrical regulations and ensure fan motor direction is correct. (Refer: **Figure 6** and **Figure 7**.)

7. MAINTENANCE INSTRUCTIONS

- Buffalo Trident condensers require low maintenance, apart from regular cleaning of the fin face. Frequency is dependent upon the operating environment of the condenser.
- It is recommended that fin surfaces are cleaned using a soft bristle brush and/ or low pressure water, taking care to avoid all electrical components. **(Electrical power must be isolated prior to cleaning.)**
- All fan motors contain sealed bearings and are maintenance free.

8. DECOMMISSIONING INSTRUCTIONS

- Pump down refrigeration system into the receiver or suitable container. (As per “Refrigeration Code of Good Practice”*)
- Isolate power and remove electrical wiring (**remove earth wire last**) and associated components where necessary.
- Disconnect refrigeration piping and seal both the system and condenser connections. **(Ensure that positive/negative pressure does not exist in condenser prior to disconnection.)**
- Condenser can now be removed from location. (The use of lifting devices during removal is recommended where applicable.)
- **“Code of Good Practice” produced in conjunction with AFCAM.**