



BFK Bi-flow Filter Drier Technical Data



ALCO BFK is a hermetic Bi-flow filter-drier in solid block style for use on liquid line in reversible refrigeration systems such as heat pump units.

Features

- Solid block style
- Integrated check valves insure Bi-flow capability, eliminate the need for external check valves and reduce the external piping
- Hermetic design
- Pattern flow for non-turbulent performance
- Patented internal check valves design
- Rugged steel shells
- Copper ODF connections for easy brazing
- Corrosion resistant epoxy powder painting
- High water, acid adsorption capacity
- High filtration capacity / efficiency
- Compatibility with all new refrigerants / lubricants

Options

- Other connections upon request, minimum 500 pieces order quantity



**BFK
Bi-flow Filter Drier**

Introduction

Liquid line filter-driers are often referred to as system protectors because they remove harmful elements from the circulating refrigerants and lubricants before serious damage results. No matter how many precautions are taken during assembly and installation or servicing of a system, contaminants can find (generate) their way into the system. These contaminants can be solid, such as metal swarf, flux, dust and dirt. Other equally menacing contaminants are soluble, such as water, acid and wax.

Construction

The active drying material is in the form of solid block. The solid block is a mixture of molecular Sieve and Activated Alumina. These adsorbent are formed into a solid block and are held together by a **Synthetic binding material**. The solid block is held tightly at both ends. The cushion felt pads for protection of the block are located at the ends of the block. The internal check valves deflect flow in order the BFK be suitable for installation in Bi-flow directional of liquid in heat pump systems.

The internal block and felt pads insure the proper filtration.

ALCO BFK filter-driers incorporate a desiccant specially formulated and blended from 75% Molecular Sieves and 25% Activated Alumina for maximum moisture and sufficient acid removal capability.

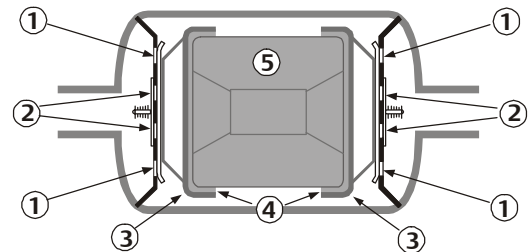

- (1) = Inlet Flopper Valve
- (2) = Outlet Poppet Valve
- (3) = Steel Retaining Screen
- (4) = Final Filter Pad
- (5) = Moulded Desiccant Block

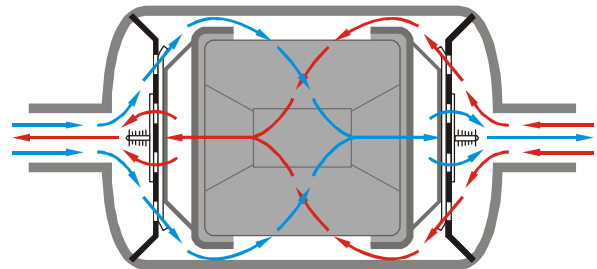

Moisture removal capability

The most popular and effective desiccant in use today for removal of moisture from refrigerants and lubricants is molecular sieves which can hold three to four times the water of other commercial adsorbents. Molecular Sieves are synthetically produced Crystalline metal Alumina-Silicates. The extreme high porous adsorbents have strong affinity for water. In contrast to the other adsorbents, the pores of any particular type of Molecular Sieves are precisely uniform in size.

Molecular Sieves with 3 Angstrom pore size are used in BFK. These Molecular Sieves are compatible with CFCs, HCFCs, HFCs, mineral, Alkylbenze and ester lubricants as well as with small size of molecules of R22.

Acid pick-up capability

The various organic acids generation is due to the decomposition, chemical reaction and hydrolysis of the refrigerants, lubricants and foreign substances in refrigeration system. The major factor which can accelerate the process of acid generation are the excessive temperatures. It is important that any generated acid in a system is adsorbed as soon as it is formed.

It is known, that POE lubricants that are being used with HFC refrigerants are susceptible to hydrolysis in the presence of moisture and heat. The reaction products of this hydrolysis include organic acids with low molecular weight, which may corrode metals. The other resultant effect is the produced solid salt which is harmful for moving parts of a compressor such as bearing and shaft.

Activated Alumina is the best desiccant to adsorb organic acids.

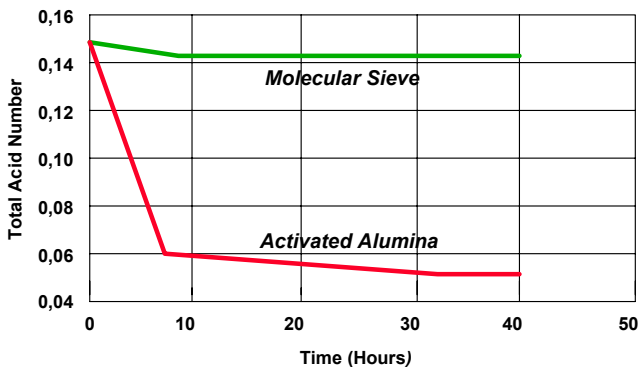

Other commercial adsorbents do not remove organic acids.

There are different types of Activated Alumina. The application of these adsorbents are dependent on the manufacturing process, binding material and style such as block or compacted beads. Alco BFK incorporated a type of Activated Alumina with very high organic acid adsorption capacity.

Filtration capability

The presence of various contaminants in refrigeration systems has been one of major concern to equipment manufacturers, installers and design engineers. The source of contaminants are typically from manufacturing, installation and by-products during operation from wear process and various chemical reactions. Typical contaminants include pure copper, copper oxides, iron,

iron oxides, brazing flux, filings, aluminium, zinc, chromium and dirt among others. In addition, due to the solvent nature of the POE lubricants, which result of the cleaning of refrigeration circuit, the filtration capability of filter driers becomes more important.

The filter drier must be able to hold most of particles whereas maintaining flow capacity at reasonable pressure drops. ALCO BFK filter-driers are designed to trap and hold large quantities of solid particles or semi-solids such as sludge circulating in a system while maintaining acceptable flow rates during their service life.

Polyol ester lubricants and filter-drier selection

The introduction of new HFC refrigerants which are not miscible with traditional mineral oil and Alkylbenzene lubricants has created the requirements for polyol ester (POE) lubricants. POEs have some inherent characteristics that require special attention when using the lubricant. These two characteristics, lubricant decomposition and hygroscopicity, are interactive in nature under certain conditions and the conditions for this interaction are not difficult to obtain in field installed refrigerant systems.

POE is made from a reaction between ester acids and alcohol. The net product is POE lubricant and water. The water is driven off and what remains is the POE lubricant that ends up in the cans. The key point to remember about this reaction is that it can be reversible, in other words, combining POE lubricant and water in a contaminated system can create acids and small amounts of alcohol.

From laboratory testing, we know that moisture levels as low as 75 ppm can allow acid to form.

The higher the moisture content of the POE the greater is the chance of acid formation.

This situation described above is aggravated by the POE's affinity for moisture. In field piped systems where it is extremely difficult to prevent moisture infiltration into piping and components, POEs have the opportunity to adsorb moisture creating the condition for acid formation.

High moisture capacity driers can remove moisture from a system and the POE but several important points must be kept in mind:

- A 100% molecular sieve drier has no capacity to adsorb acids formed by POE decomposition.
- At water levels above 75 ppm it is possible for POE to break down into acids.
- A drier that is saturated with moisture allows the remaining free moisture to react with the POE thus forming acids.
- A drier does not remove moisture in a single pass therefore it is possible to form acids even before the drier has a chance to remove moisture.

Based on these points, the selection of a drier for use with POE lubricants must be based on the ability to remove a high degree of moisture as well as some capacity for removing generated acids.

Application

1. Heat pumps with two expansion valves and external check valves

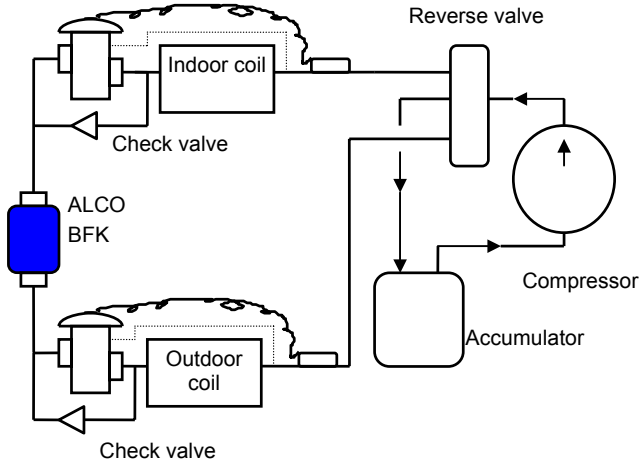

2. Heat pumps with two expansion valves having internal check valves

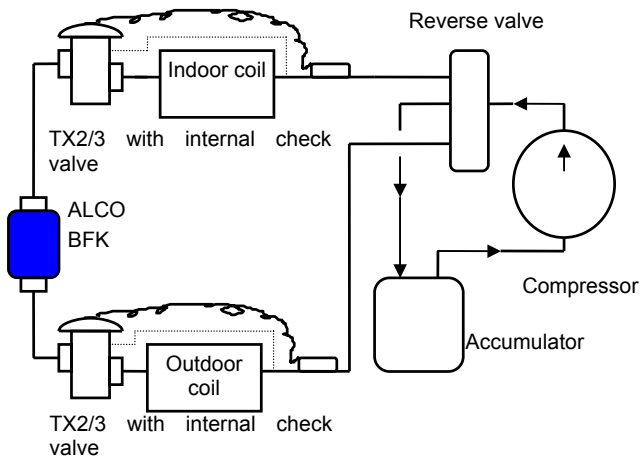

3. Heat pumps with larger capacity

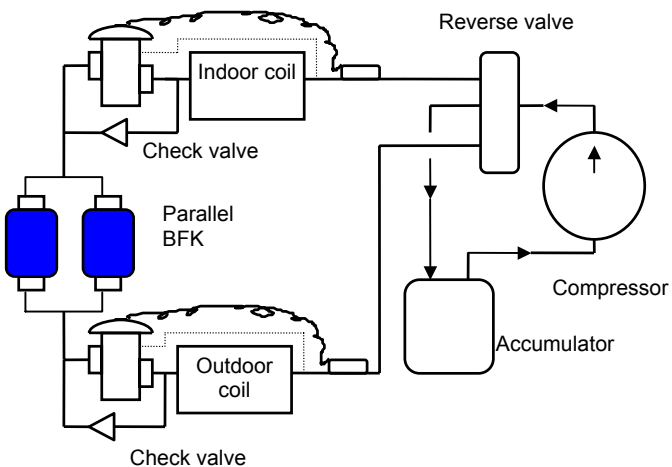

4. Heat pumps with Bi-flow expansion valve

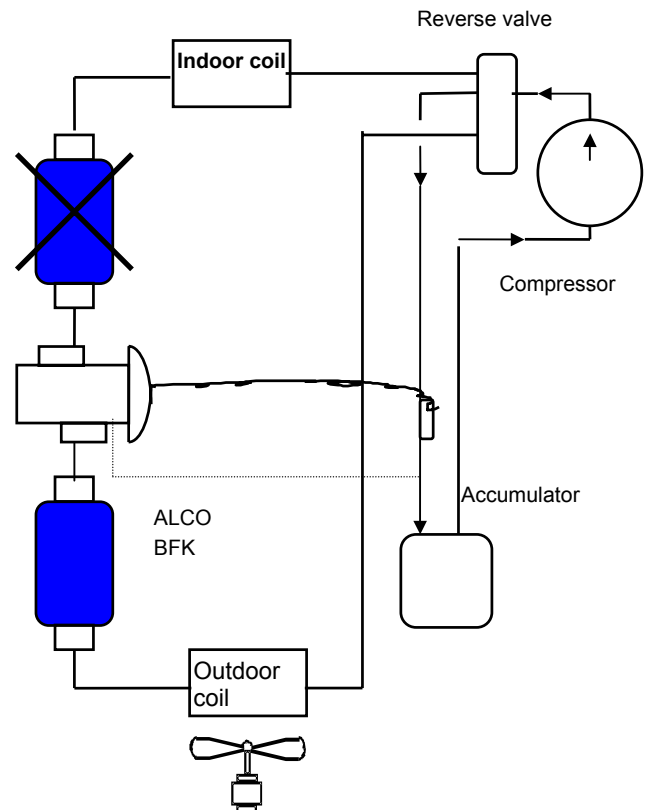

Note:

It is important that BFK in this type of application to be installed between Bi-flow expansion valve and outdoor coil.



BFK Bi-flow Filter Drier



Selection method

Given the proper liquid line size and style connection, select filter-drier as follow:

1. Determine the correction factor (next page) based on type of refrigerant, liquid and evaporating temperature
2. Multiply the correction factor by cooling capacity or heating capacity whatever is more.
3. Select the filter drier according to determined capacity corresponding to flow capacity at 0.07 bar pressure drop.

Example: Heat pump with 1/2" liquid line, refrigerant R22, cooling capacity 12 kW at +5°C/55°C and heating capacity 8 kW at -10°C/+35°C

Correction factor in cooling mode: 1.24

Required capacity: 12x1.24 = 14.9 kW

Correction factor in heating mode: 1.04

Required capacity: 8x1.04 = 8.3 kW

Select BFK-084S having 17 kW flow capacity at 0.07 bar pressure drop.

Selection table

Type	Part Code Nr.	Connection size & type	Unit size	Flow capacity in kW @ 0.07 bar ΔP					Flow capacity in kW @ 0.14 bar ΔP				
				Refrigerant					Refrigerant				
				R22	R407C	R410A	R134a	R404A R507	R22	R407C	R410A	R134a	R404A R507
BFK-052	007 343	1/4"(6mm) SAE	5	5.7	5.4	5.6	5.2	3.7	8.8	8.4	8.7	8.0	5.7
BFK-052S	007 344	1/4" ODF		7.3	7.0	7.2	6.7	4.8	11.1	10.6	10.9	10.1	7.2
BFK-083	007 345	3/8"(10mm) SAE	8	11.5	11.0	11.4	10.6	7.5	18.4	17.6	18.2	16.9	12.0
BFK-083S	007 346	3/8" ODF		13.1	12.5	12.9	12.0	8.5	22.5	21.5	22.2	20.6	14.7
BFK-084	007 347	1/2"(12mm) SAE		16.6	15.8	16.4	15.2	10.8	28.1	26.8	27.8	25.8	18.3
BFK-084S	007 348	1/2" ODF		17.0	16.2	16.8	15.6	11.1	31.3	29.9	30.9	28.7	20.4
BFK-163	007 349	3/8"(10mm) SAE	16	14.9	14.2	14.7	13.6	9.7	22.9	21.8	22.6	21.0	14.9
BFK-163S	007 350	3/8" ODF		16.9	16.1	16.7	15.5	11.0	26.0	24.8	25.7	23.8	17.0
BFK-164	007 351	1/2"(12mm) SAE		22.1	21.1	21.9	20.3	14.4	30.0	28.6	29.6	27.5	19.6
BFK-164S	007 352	1/2" ODF		26.5	25.3	26.1	24.3	17.3	37.6	35.9	37.1	34.4	24.5
BFK-165	007 353	5/8"(16mm) SAE		27.4	26.2	27.1	25.1	17.9	38.5	36.8	38.0	35.3	25.1
BFK-165S	007 354	5/8" ODF		28.0	26.7	27.6	25.6	18.3	40.4	38.5	39.9	37.0	26.3
BFK-305	007 355	5/8"(16mm) SAE	30	28.8	27.5	28.5	26.4	18.8	45.4	43.3	44.8	41.6	29.6
BFK-305S	007 356	5/8" (16mm) ODF		37.3	35.6	36.8	34.1	24.3	57.7	55.0	56.9	52.8	37.6
BFK-307S	007 357	7/8" (22mm) ODF		44.3	42.3	43.7	40.6	28.9	71.7	68.4	70.8	65.7	46.8
BFK-309S	007 358	1-1/8" ODF		51.3	49.0	50.7	47.0	33.5	87.2	83.2	86.1	79.9	56.9

Note: Published flow capacity at 0.14 bar are for performance comparison. Select the filter drier always at 0.07 bar pressure drop. Higher pressure drop will either created flash gas in liquid line or eliminated the subcooling of liquid refrigerant.

Flow rates

The rated flow capacities are in accordance with ARI standard 710-86 and DIN 8949 at +30°C liquid temperature and -15°C evaporating temperature.

For other temperatures, please use the correction factor.

Flow rates: 0.0062 kg/kW/sec. for R22

Flow rates: 0.0063 kg/kW/sec. for R407C

Flow rates: 0.0059 kg/kW/sec. for R410A

Flow rates: 0.0068 kg/kW/sec. for R134a

Flow rates: 0.0088 kg/kW/sec. for R404A/R507



BFK Bi-flow Filter Drier



Correction factors

Refrigerant	Liquid temperature °C	Evaporating temperature °C									
		15	10	5	0	-5	-10	-15	-20	-25	-30
R22	60	1.29	1.30	1.32	1.34	1.36	1.38	1.40	1.42	1.45	1.48
	55	1.21	1.23	1.24	1.26	1.27	1.29	1.31	1.33	1.35	1.38
	50	1.14	1.16	1.17	1.18	1.20	1.22	1.23	1.25	1.27	1.29
	45	1.08	1.09	1.11	1.12	1.13	1.15	1.16	1.18	1.20	1.22
	40	1.03	1.04	1.05	1.06	1.08	1.09	1.10	1.12	1.14	1.15
	35	0.98	0.99	1.00	1.01	1.02	1.04	1.05	1.06	1.08	1.09
	30	0.94	0.95	0.96	0.97	0.98	0.99	1.00	1.01	1.03	1.04
	25	0.90	0.91	0.91	0.92	0.93	0.94	0.95	0.97	0.98	0.99
R407C	60	1.42	1.45	1.49	1.52	1.56	1.61	1.65	1.70	1.76	1.82
	55	1.29	1.32	1.35	1.38	1.41	1.44	1.48	1.52	1.57	1.61
	50	1.19	1.21	1.23	1.26	1.28	1.31	1.35	1.38	1.42	1.46
	45	1.10	1.12	1.14	1.16	1.18	1.21	1.24	1.26	1.30	1.33
	40	1.02	1.04	1.06	1.08	1.10	1.12	1.14	1.17	1.20	1.22
	35	0.96	0.98	0.99	1.01	1.03	1.05	1.07	1.09	1.11	1.14
	30	0.91	0.92	0.93	0.95	0.96	0.98	1.00	1.02	1.04	1.06
	25	0.86	0.87	0.88	0.90	0.91	0.93	0.94	0.96	0.98	1.00
R410A	60	1.64	1.66	1.68	1.70	1.73	1.76	1.80	1.83	1.87	1.92
	55	1.43	1.44	1.46	1.48	1.50	1.53	1.55	1.58	1.61	1.64
	50	1.28	1.29	1.31	1.32	1.34	1.36	1.38	1.40	1.43	1.45
	45	1.17	1.18	1.19	1.20	1.22	1.24	1.25	1.27	1.29	1.31
	40	1.08	1.09	1.10	1.11	1.12	1.14	1.15	1.17	1.18	1.20
	35	1.01	1.01	1.02	1.03	1.04	1.06	1.07	1.08	1.10	1.11
	30	0.94	0.95	0.96	0.97	0.98	0.99	1.00	1.01	1.03	1.04
	25	0.89	0.90	0.90	0.91	0.92	0.93	0.94	0.95	0.96	0.98
R134a	60	1.32	1.35	1.39	1.42	1.46	1.50	1.55	1.59	1.65	1.70
	55	1.22	1.25	1.28	1.31	1.34	1.38	1.41	1.45	1.50	1.54
	50	1.14	1.16	1.19	1.21	1.24	1.27	1.30	1.34	1.38	1.42
	45	1.06	1.09	1.11	1.13	1.16	1.18	1.21	1.24	1.27	1.31
	40	1.00	1.02	1.04	1.06	1.08	1.11	1.13	1.16	1.19	1.22
	35	0.94	0.96	0.98	1.00	1.02	1.04	1.06	1.08	1.11	1.14
	30	0.90	0.91	0.93	0.94	0.96	0.98	1.00	1.02	1.04	1.07
	25	0.85	0.86	0.88	0.89	0.91	0.93	0.95	0.96	0.98	1.01
R404A R507	60	1.83	1.90	1.97	2.06	2.16	2.27	2.39	2.54	2.70	2.89
	55	1.52	1.56	1.62	1.67	1.74	1.81	1.90	1.99	2.09	2.21
	50	1.31	1.34	1.38	1.43	1.47	1.53	1.59	1.65	1.73	1.81
	45	1.16	1.18	1.21	1.25	1.29	1.33	1.38	1.43	1.48	1.54
	40	1.04	1.06	1.09	1.12	1.15	1.18	1.22	1.26	1.30	1.35
	35	0.95	0.97	0.99	1.01	1.04	1.07	1.10	1.13	1.17	1.20
	30	0.87	0.89	0.91	0.93	0.95	0.97	1.00	1.03	1.06	1.09
	25	0.81	0.83	0.84	0.86	0.88	0.90	0.92	0.94	0.97	1.00



BFK Bi-flow Filter Drier



Technical data

Maximum working pressure PS	43 bar
Factory test pressure PT	47,3 bar
Temperature Range TS	-40°C to +65°C
Final filtration	> 40 micron
Package	Individual packaged
Compatibility	CFC, HCFC, HFC, mineral and ester lubricants *
Installation location	BFK may be installed in any position within the liquid line

HP marking according to German pressurised vessel	HP, CE marking not necessary
Approvals	UL
Paint	Epoxy powder paint
Protection	minimum 500 hours salt spray test
Solder connections	copper, ODF
Flare connections	burnished, SAE
Shell material	steel

*) ALCO BFK is not released for use with caustic, poisonous or flammable substances.

Note: All pressure are given in gauge pressure

Water adsorption capacity

Type	Unit size	24°C liquid refrigerant					52°C liquid refrigerant				
		Water adsorption capacity in grams									
		R22	R407C	R410A	R134a	R404A R507	R22	R407C	R410A	R134a	R404A R507
BFK-05...	5	4.1	3.4	2.8	4.4	4.5	3.8	2.8	2.2	4.1	4.3
BFK-08...	8	9.0	7.5	6.2	9.6	9.9	8.2	6.0	4.7	8.9	9.4
BFK-16...	16	17.7	14.8	12.2	18.9	19.5	16.2	11.9	9.3	17.5	18.5
BFK-30...	30	32.3	27.1	22.4	34.5	35.6	29.6	21.7	17.0	31.9	33.7

The water capacity for R22 refers to ARI 710-86 and DIN 8948 and it is based on a liquid temperature of 24°/52°C, an equilibrium point dryness (EPD) of 60 PPM water in refrigerant. ARI-standard does not refer to new alternative refrigerants. The EPD for other refrigerants according DIN 8949 is as follows:

Note: Compressor manufacturers request/recommend the moisture level of POE lubricant in crankcase to be less than 50 ppm.

Refrigerant	End point dryness (EPD)
R22	60 PPM
R407C, R410A, R134a, R404A, R507	50 PPM

Organic acid adsorption capacity

Type	Unit size	Acid adsorption capacity in grams
BFK-05...	5	0.3
BFK-08...	8	0.6
BFK-16...	16	1.2
BFK-30...	30	2.0

according Ashrae 63.3



BFK Bi-flow Filter Drier



Dimensions, shipping weights and standard pack quantities

Type	Connection size & type	Roughing in dimensions mm			Shipping weight kg	Standard Pack Quantity
		A	B	F		
BFK-052	1/4"(6mm) SAE	123	-	64	0.45	25
BFK-052S	1/4" ODF	106	9.5			
BFK-083	3/8"(10mm) SAE	151	-			
BFK-083S	3/8" ODF	134	11			
BFK-084	1/2"(12mm) SAE	157	-			
BFK-084S	1/2" ODF	136	12.7	76	0.90	
BFK-163	3/8"(10mm) SAE	172				
BFK-163S	3/8" ODF	155	11			
BFK-164	1/2"(12mm) SAE	177				
BFK-164S	1/2" ODF	156	12.7			
BFK-165	5/8"(16mm) SAE	189			1.7	12
BFK-165S	5/8" ODF	163	16			
BFK-305	5/8"(16mm) SAE	262				
BFK-305S	5/8" ODF	236	16			
BFK-307S	7/8" ODF	251	19			
BFK-309S	1-1/8" ODF	251	24			

Solder connection

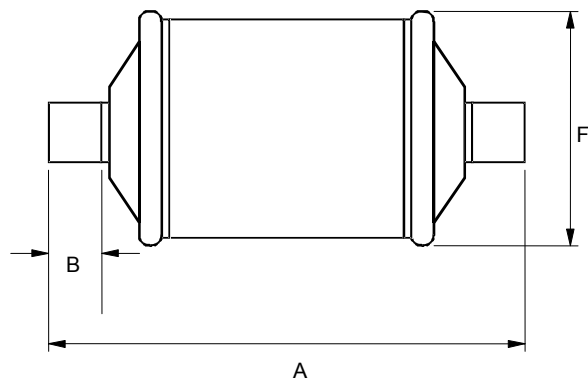

Flare connection

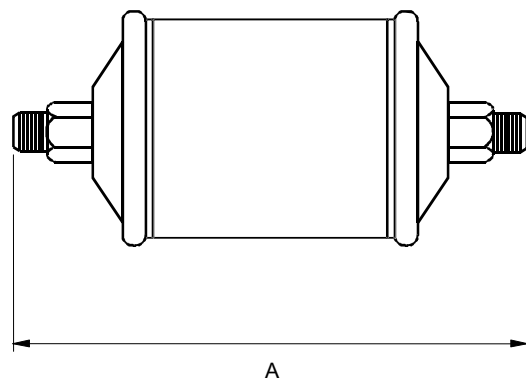



BFK Bi-flow Filter Drier



ALCO CONTROLS is not to be held responsible for erroneous literature regarding capacities, dimensions, applications, etc. stated herein. Products, specifications and data in this literature are subject to change without notice. The information given herein is based on technical data and tests which ALCO CONTROLS believes to be reliable and which are in compliance with technical knowledge of today. It is intended only

for use by persons having the appropriate technical knowledge and skills, at their own discretion and risk. Since conditions of use are outside of ALCO'S control we can not assume any liability for results obtained or damages occurred due to improper application.

This document replaces all earlier versions.

		Phone.:	Fax:
Emerson Electric GmbH & Co. OHG ALCO CONTROLS Heerstraße 111 D-71332 Waiblingen Germany Phone ...49-(0)7151-509-0 Fax ...49-(0)7151-509-200 www.eCopeland.com/alcoliterature.cfm	Benelux	+31 (0)773 240 234	+31 (0)773 240 235
	Denmark & Finland	+32 (0)87 305 565	+49 24 08 929 568
	Eastern Europe, Turkey & Iran	+32 (0)87 305 061	+32 (0)87 305 506
	France, Greece, Maghreb	+33 (0)478 668 570	+33 (0)478 668 571
	Deutschland, Österreich, Schweiz	+49 (0)6109 6059 0	+49 (0)6109 6059 40
	Italia	+39 02 961 78 1	+39 02 961 78 888
	Middle East & Africa	+97 148 832 828	+97 148 832 848
	Poland	+48 (0)22 458 9205	+48 (0)22 458 9255
	Russia & Cis	+7 495 981 9811	+7 495 981 9816
	España & Portugal	+34 93 4 123 752	+34 93 4 124 215
	Sweden & Norway	+32 (0)87 305 565	+49 24 08 929 568
	UK & Ireland	+44 (0)1 635 876 161	+44 (0)1 635 877 111