

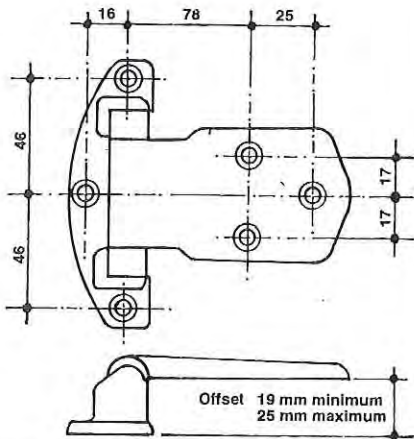

REFRIGERATION HARDWARE

LIGHT AND MEDIUM DUTY HINGES

**R31
TENSION HINGE**

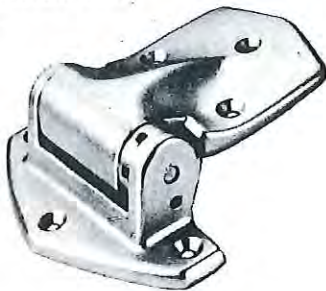

**R40
ADJUSTABLE HINGE**

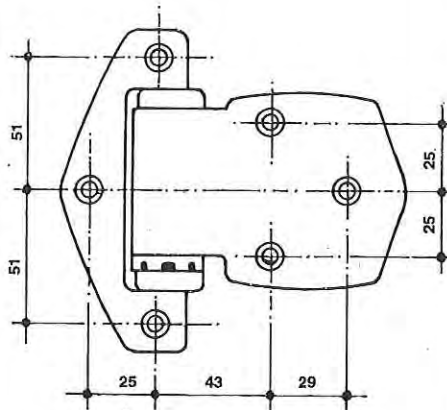
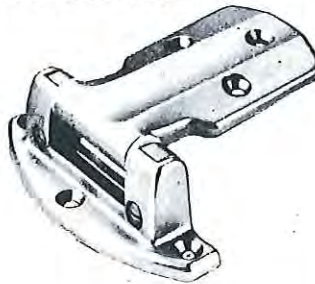

**R36
HINGE**

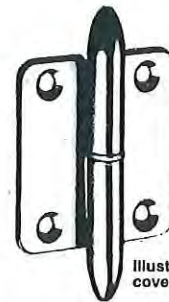

Illustrated with optional cover ferrules fitted.

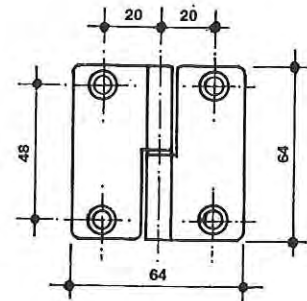

Right hand illustrated

**R52
HINGE**

R52-2C OPTIONAL COVER



R52-8C OPTIONAL COVER

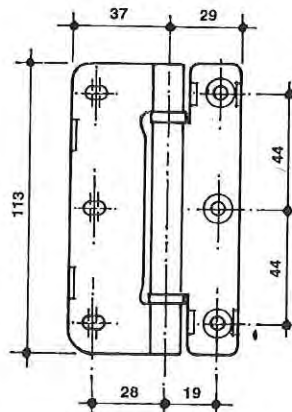

HANDING:

Handed. Please state hand when ordering.

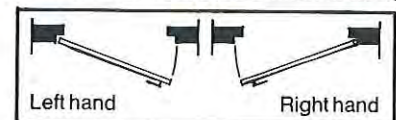

Left hand

Right hand

4

CAT. NO.	NEW PART NO.	OLD P/N	DESCRIPTION	OFFSET	APPLICATION — OPERATION SPECIFICATIONS	FINISH
2335	R31	Same	TENSION HINGE (Not handed)	19mm	Designed for use on drop-down cabinet doors. Adjustable tension loaded spring designed to counter balance door. Body, flap and tension adjusting collar - zinc machine cast. Pin - steel, zinc plated.	CHROME PLATED
23316	R40	R40A	ADJUSTABLE HINGE (Not handed)	Adj. 19mm to 25mm	Designed for use on medium size offset cabinet doors. Body and flap - zinc machine cast. Bushes - Nylon. Pin - steel, zinc plated.	
233176	R40-36C		Packing Piece for R40			
2337	R36 (RH)	Same	HINGE	NIL	Designed for use on small refig. and cabinet doors. Lift off face to face mounting with optional cover ferrules. Hinge - steel. Cover ferrules - brass.	
2338	R36 (LH)				For use with R36 Hinge	
2339	R36-V8C				COVER FERRULES	
23337	R52	R52E	HINGE (Not handed)	NIL	Designed for use on small refig. and cabinet doors. Face to face mounting with optional covers for both blades to conceal fixing. Hinge - steel. Covers - brass.	
23346	R52-8C	R52E	Small Cover		For use with R52 Hinge	
23347	R52-2C		Large Cover		For use with R52 Hinge	

All EFCO products shown in this catalogue are manufactured in Imperial sizes. Dimensions shown are nominal. Metric equivalents.



REFRIGERATION HARDWARE

LIGHT AND MEDIUM DUTY HINGES

R100 HINGE

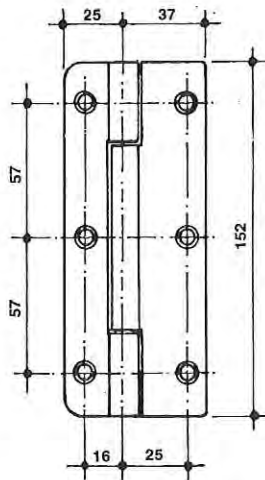
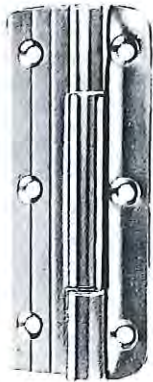

R183 PIVOT HINGE

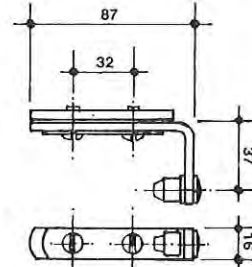

R187 RISING HINGE

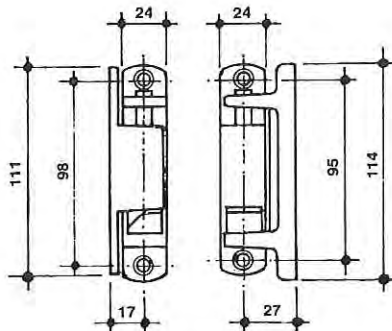

Right hand illustrated

HANDING:
Handed. Please state hand when ordering.

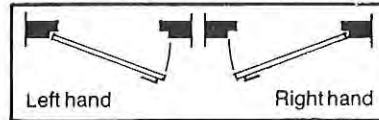

CAT. NO.	NEW PART NO.	OLD P/N	DESCRIPTION	OFFSET	APPLICATION — OPERATION SPECIFICATIONS	FINISH
233126	R100	R100E	HINGE (Not handed)	NIL	Designed for use on refrigerator and cabinet doors. Face to face fixing Flaps - brass. Pin - steel.	CHROME PLATED
233150	R183	Same Note: Centre Hinge NLA	PIVOT HINGE (Top & Bottom) (Not handed)	NIL	Designed for use on medium size face-on cabinet doors. Pivot for both top and bottom of face-on doors, adjustable for gasket pressure. Supplied with tapping plate, backing strip, cover strip and screws. Tapping plate - steel, zinc plated. Back.strip & bushes-Nylon.	
233154	R187(RH)	Same	RISING HINGE (RH & LH)	NIL	Designed for use on self-service cabinets. Self closing rising hinge. Opens to 180°. Designed to close door from approx. 90°. Supplied with packing strips and Tapping plates.	
233155	R187(LH)				Hinge flaps - zinc machine cast. Rising cams - delrin.	
233168	R187-V8	R187			Packing Strips for R187.	
233169	R187-V9C	R187			Tapping Plates for R187.	

All EFCO products shown in this catalogue are manufactured in Imperial sizes
Dimensions shown are nominal Metric equivalents.

GET THE RIGHT PRODUCT

NO SENSE ACCEPTING A SUBSTITUTE PART INSTEAD OF ONE THAT YOU WANT TO BUY BUT WHICH IS NOT CARRIED IN STOCK BY MOST SUPPLY HOUSES. THE PART THAT YOU THINK "WILL DO" MAY ULTIMATELY COST YOU YOUR PROFIT ON THE JOB AS WELL AS A LOST CUSTOMER. PICK OUT THE RIGHT PART YOU WANT FROM THIS CATALOGUE AND CHANCES ARE GOOD THAT WE'LL HAVE IT. IF NOT, WE WILL GET IT FOR YOU AS QUICKLY AS POSSIBLE.



**REFRIGERATION HARDWARE
CABINET HARDWARE**

R1161 LATCH MOVEMENT

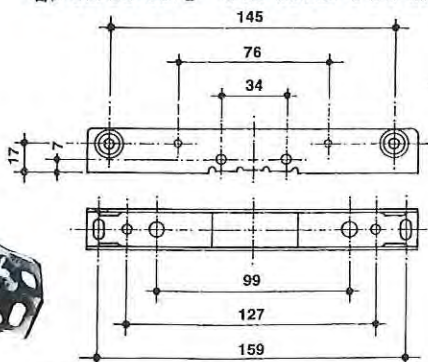
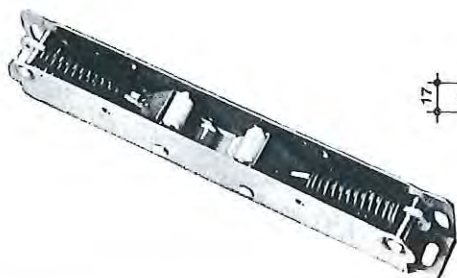

R1191 LATCH MOVEMENT

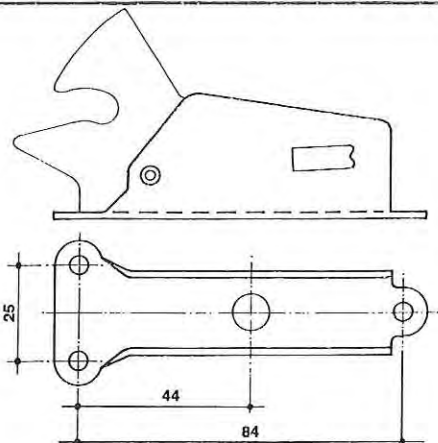
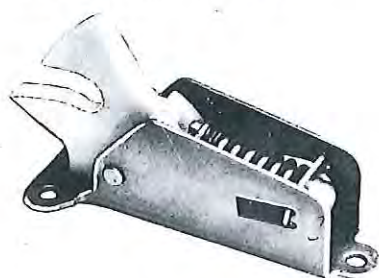

R1162 STRIKE

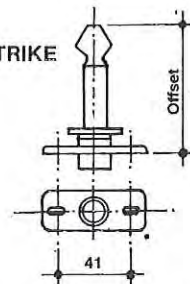

R1163 STRIKE

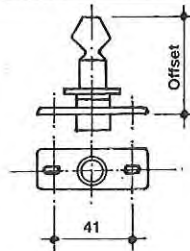

R1192 STRIKE

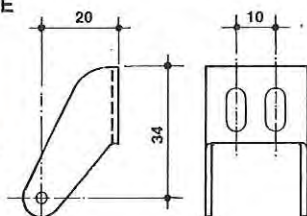

4

CAT. NO.	NEW P/N	OLD P/N	DESCRIPT.	DETAILS
223127	R1161	R116A	LATCH	For mounting inside cabinets. Conforms with safety requirements of easy escape from interior of cabinet. Double rollers with double springs provide gasket compression. Spring tension 7.3 kg (1 lb) not adjustable. Body — steel zinc plated. Rollers — Nylon.
233128	R1162	R116B	STRIKE	For use with R1161 Latch. Face mounted. Adjustable offset 25-70 mm. Zinc machine cast. Chrome finish.
233129	R1163	R116J	STRIKE	For use with R1161 Latch. Face mounted. Adjustable offset 25-54 mm. Zinc machine cast. Chrome finish.
233132	R1191	R119	LATCH	For mounting inside cabinets. Conforms with safety requirements for easy escape from interior of cabinet. Spring loaded toggle action. Body — steel zinc plated. Beak — Nylon.
233131	R1192	R119	STRIKE	For use with R1191 Latch. Face mounted. Adjustable offset 0-5 mm. Mounting Bracket — Stainless steel. Roller — Nylon. Finish — Satin Stainless Steel.

HANDLES

FINISH: CHROME PLATED
MATERIAL: ZINC MACHINE CAST

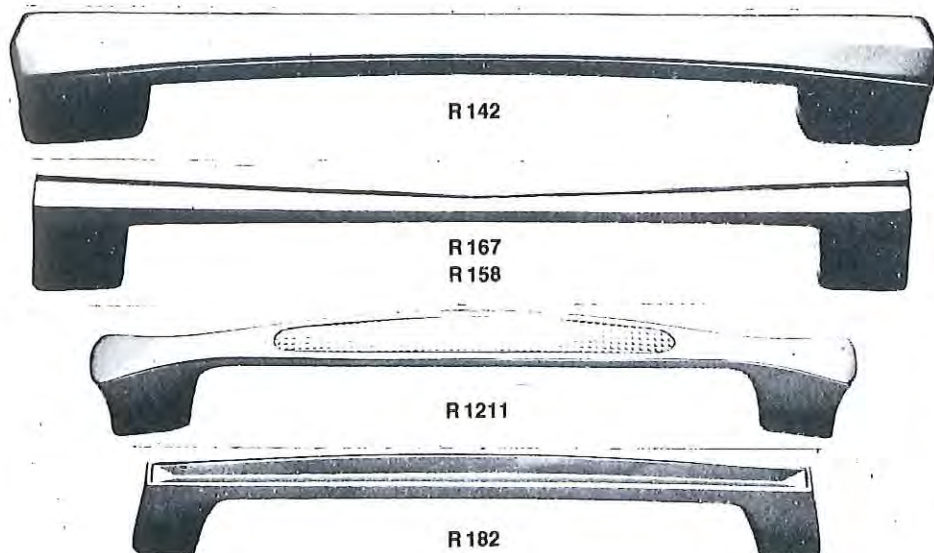

CAT. NO.	Part No.	Clearance mm	Mount. Hole Centres mm	O/A Lgth. mm
233146	R142	40	222	260
233147	R158	40	220	262
233148	R167	40	470	506
233145	R182	34	197	215
233134	R1211	43	222	250
233181	R61*			75

* Not Illustrated

233-e



REFRIGERATION HARDWARE

LATCHES, LOCKS AND PARTITION FASTENERS

R 1951
MAGNETIC
LATCH



R 1952
MAGNETIC
LOCK



R 196 SERIES LATCHES

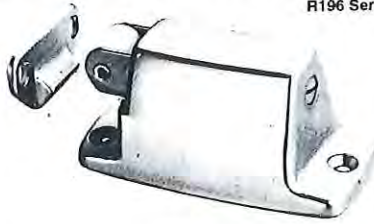

Dimensions apply also to R196 Series Locks.

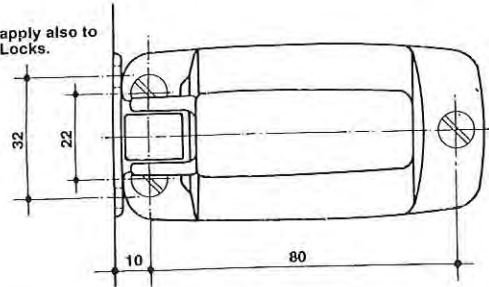

R 196 SERIES LOCKS

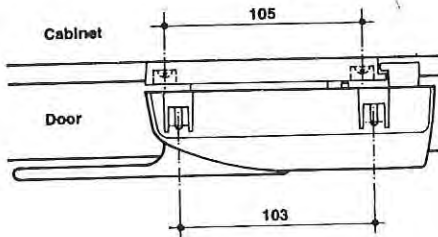
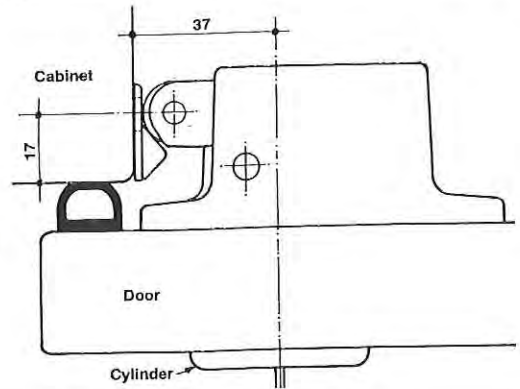

R 161 PARTITION FASTENER

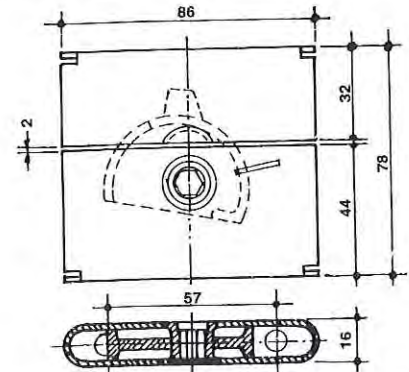

CAT. NO.	NEW PART NO.	OLD P/N	DESCRIPTION	ADJUST.	APPLICATION — OPERATION SPECIFICATIONS	FINISH
233157	R1951	R195	MAGNETIC LATCH		For use with face-on type doors on display cabinets in conjunction with R187 Hinges. Edge fixed to door, magnetic attraction holds latch against base plate (mean pressure 8.18kg) Pulling handle operates pin to break attraction (force required 1300g) MAGNETIC LOCK OPERATION : Same as above but key operates toggle which engages in strike plate. Lock must be fitted with cylinder at the bottom as illustrated Case, handle and base - zinc machine cast. Magnet - iron.	CHROME PLATED
233156	R1952	MAGNETIC LOCK				
233158	V2001	LOCK		Lock Cylinder		
233159	R1951-V13A	STRIKE		Strike Assembly		
	R1951-V17C	TRACTION ADAPTER			Fits over end of handle of Magnetic Latch/Lock and is joined by 17mm I.D. bar.	
233162	R1961	R196 Light Spring	R196 SERIES LATCHES	6.8 to 16.3 kg	For use inside cabinets Spring loaded roller, adjustable for spring tension. Body and strike - zinc machine cast. Roller - Nylon.	ZINC PLATED
233165	R1962	R196 Hvy. Spring		12.7 to 31.8 kg		
233163	R1963	R196 Light Spring	R196 SERIES LOCKS	6.8 to 16.3 kg	For use inside cabinets. Spring loaded roller, adjustable for spring tension. Operated by key from outside. Uses standard rim night latch cylinder (supplied). Master keying or keying alike available to order. Press button safety release from inside. Body and Strike - zinc machine cast. Roller and safety release - Nylon. Cylinder - brass, 6-pin tumbler.	
233166	R1964	R196 Heavy Spring		12.7 to 31.8 kg		
233149	R161	Same	PARTITION FASTENER		For use in the erection of pre-fabricated coolrooms. Mortised into edge or face of panel, eccentric cam pulls sections together and locks in place. Tightened by hexagonal key - not supplied as standard Case and Strike - steel, zinc plated. Cam - zinc machine cast. Key - steel 6.4 mm across flats.	
233174	V2101C	R162 Key	KEY		Hexagonal Key for R161.	
233139	V2301C	R161 Grey Butt.	PLUG		Grey plastic, for filling key hole in panel - for use with R161.	

All EFCO products shown in this catalogue are manufactured in Imperial sizes
Dimensions shown are nominal Metric equivalents

KASON REFRIGERATOR HARDWARE

1245 CAM-LIFT REVERSIBLE HINGES

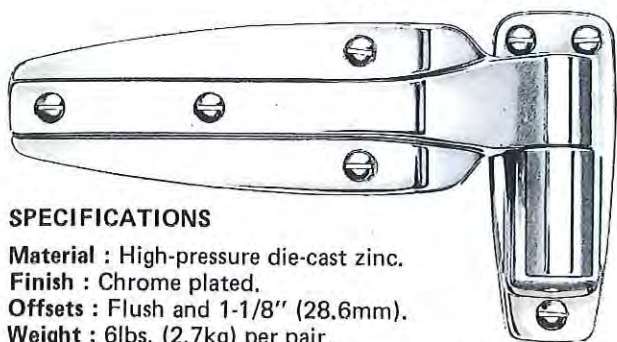

SPECIFICATIONS

Material : High-pressure die-cast zinc.
Finish : Chrome plated.
Offsets : Flush and 1-1/8" (28.6mm).
Weight : 6lbs. (2.7kg) per pair.
 Drilled and countersunk for 1/4" (6.0mm) flat head screw.

"Switch-Hitter" hinges? Right! Because our new 1245 hinges are completely reversible in just minutes. And that neat little feature makes these new hinges easier to inventory, faster to install, helps eliminate installation mistakes!

Each hinge is of cam-life design, with cams made of self-lubricating nylon, precision moulded to deliver perfect rise. All contact is nylon-to-nylon which guarantees smooth, trouble-free door operation; there is no nylon-to-metal contact. And the "lift action" helps eliminate wear on the gasket, even where irregular floors are involved.

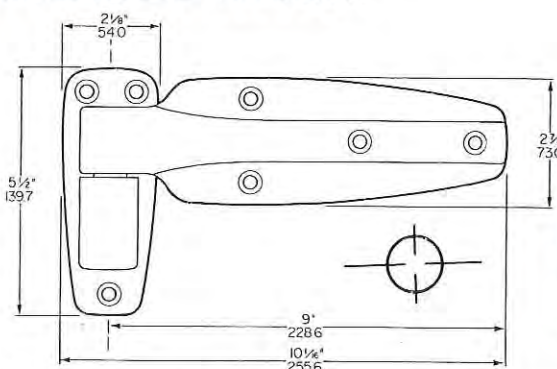

CAT. NO.
Flush 233240
Offset 233241

Each hinge is self-closing because of the cam action which returns the door smoothly, firmly to the closed position. However, the built-in "dwell-stop" is designed to keep the door open if swung beyond the 90 degree position.

Each hinge has a lift-off feature for more efficient, more economical installation and shipping. Doors fitted with these hinges can be lifted off without removal of hinge parts. Also, doors without sweeper gaskets can be used in right or left hand positions even after straps have been fastened to the door.

Look at how easy it is to reverse these Kason Switch - Hitter Hinges !



To reverse the 1245 lift strap from flange.

Remove pin assembly.

Pop out the cap.

Turn strap 180°, reinsert pin assembly in strap.

Reposition strap into flange, and replace cap.

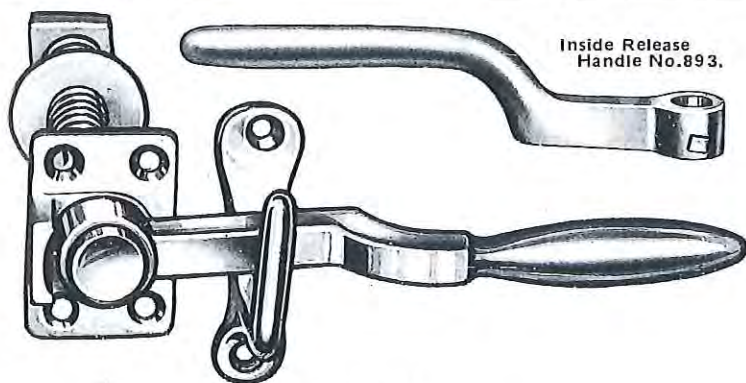

SPECIFICATIONS

METALS : Lever Handles in Brass Chromium plated.
 Offset Block is high pressure Zinc die-casting.
OFFSETS : Flush.
 Rods for inside release handles are threaded 7".
 Drilled and countersunk for No. 10 screws.
 Weight per lever — approx. 1-7/8lbs. (.85kg).

CAT. NO.	233236
-----------------	--------

WEDGE TYPE LEVER WITH INSIDE RELEASE HANDLE No. 878

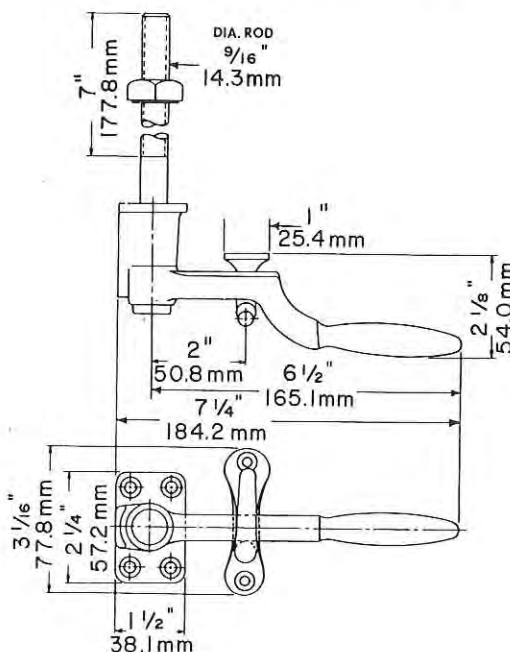

233-g

KASON REFRIGERATOR HARDWARE

SLIMLINE EDGEMOUNT LATCH

With Inside Release Handle for walk-in doors.

Your walk-ins can look even better with these handsome Slim-line Edgemount Latches. The No. 176 mounts on the edge of the door. No holes need be drilled into the face of the door. No danger of entrapment whether door is locked or simply latched. Door can be opened from inside with unique release mechanism.

Designed for lightweight foamed doors.

Adjustable Strike

Strikes for 176 latch assemblies are furnished with 4-way adjustment feature. A serrated plate is an integral part of the release mechanism; permits rigid up and down positioning of the strike to compensate for door sag. A turn of the screw assures in and out adjustments to accommodate varying gasket sizes and to adjust for gasket wear.

Inside Release Handle

Handle, face plate, and rod are made of a tough, non-conductive, non-corrosive material. Specify wall thickness with order.

SPECIFICATIONS

Material: Die-cast zinc

Finish: Highly polished chromium plated

Inside Release Handle.

Material: Housing and strike are die-cast zinc.

Flange and knob are cycolac.

Rod is nylon.

Finish: Highly polished chromium plated.

Screw Sizes: Housing drilled and countersunk for 1/4" (6.0mm) flat head screws.

Flange drilled for No.10 (5.0mm) round head screws.

Weight: Approx.12.5 lbs.(5.7kg) per carton.

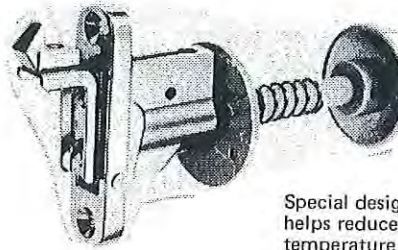

Special design helps reduce temperature loss and condensation around the latch.

No. 176 Series

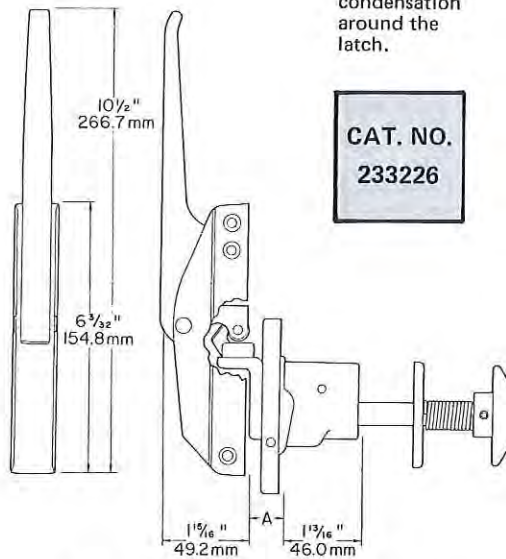

CAT. NO. 233226

"A" is adjustable from 25/32" (19.8 mm) to 1-3/32" (27.8 mm)

HEAVY DUTY IRON LATCHES No. K-52

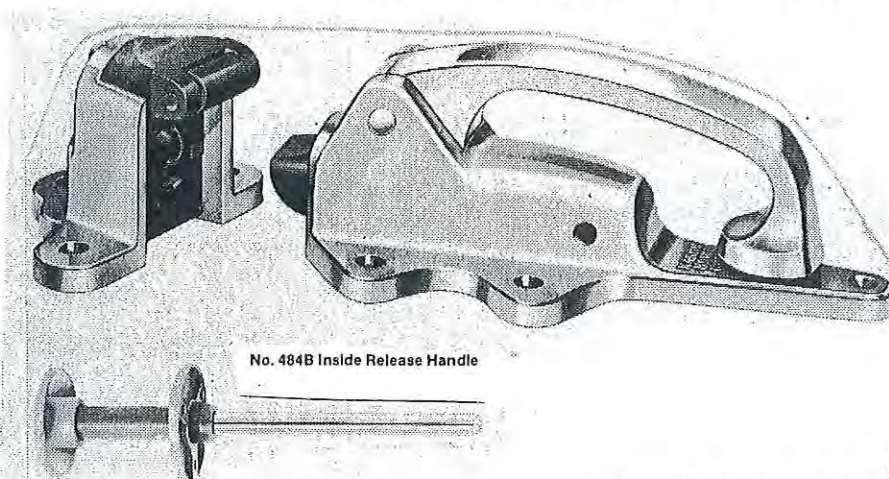

No. 484B Inside Release Handle

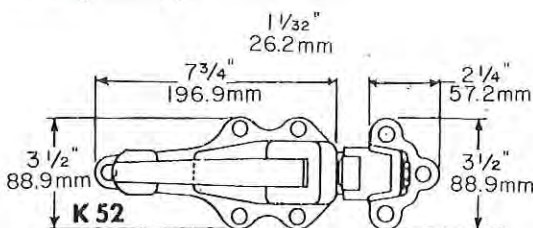

CAT. NO. 233227

FOR MEDIUM SIZE DOORS

WEIGHT: Approximately 6 3/4 lbs.(3.1kg) per box.

DRILLED & COUNTERSUNK: Body is drilled and countersunk for No. 1/4" screws. Strike is drilled for 5/16" lag screws.

Latch can be used for either right or left-hand doors.

Provision is made on latch for attaching padlock.

SPECIFICATIONS

METALS: Body & Strike Housings - Cast iron. Handle - Malleable iron.

FINISH: KASONIZED.

OFFSETS: Adjustable Strikes furnished for the range of 3/4" to 1-3/8".

INSIDE RELEASE HANDLES

MATERIAL: Rod: steel. Sleeve: Cycolac.

FINISH: KASONIZED

INSULATORS: Cycolac.

Latch No. K-52 is furnished with release handles for standard 6" (152.4 mm) doors.

KASON REFRIGERATOR HARDWARE COOLROOM LOCK SETS

K56 — HEAVY DUTY & K58 — MEDIUM DUTY



K56



K58

No. 484
INSIDE RELEASE
HANDLE

ABSOLUTE SAFETY

Complete safety is assured and Inside Release functions even when padlocked outside.

EASY POSITIVE ACTION

The No. 56 Latch is mechanically perfected to provide easy action for opening and closing refrigerator doors. Latch is released from inside or outside with minimum pressure or pull. Latch pulls into positive airtight closure with each simple operation.

COMPACT SIZE — RUGGED CONSTRUCTION

No. 56 Series Latches project only 2 1/4" from the door surface. Especially designed in keeping with the trend for lighter doors.

FREE-ACTING HANDLE

Latching action of the 56 Series works independently of handle. There is no kick or jarring of handle when door is slammed shut.

PILFER-PROOF

No. 56 Latch is fool-proof and pilfer-proof. When padlocked latch cannot be jimmied open nor can the tongue be forced to release latch.

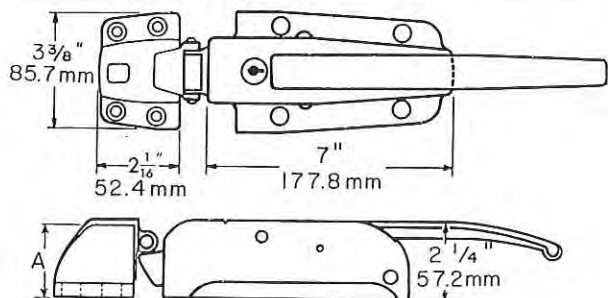

SPECIFICATIONS

Material: Body and strike: high pressure die-case zinc
Handle: forged brass, malleable iron, or forged aluminium.

Finish: Highly polished chromium, brushed chrome, Two-tone chrome
All lacquered
Lacquered latch with polished chrome handle

Offsets: Adjustable from :
1/8" (3.2mm) below flush to 1/4" (6.4mm) above flush.
3/4" (19.1mm) to 1 1/2" (38.1mm) above flush.

Weight: 8 lbs. (3.6kg) per latch.

CAT. NO.	
Offset	233233
Flush	233234



Adjustable strikes assure perfect door seals. Adjustments from 3/4" (19.1mm) to 1 1/2" (38.1mm)

CAT. NO.
233235

ABSOLUTE SAFETY

Latch can be opened from the inside with inside release handles . . . even if the latch is padlocked outside.

UNIQUE DESIGN FOR SMOOTHEST ACTION

New radial tongue design with rolling-pivot action guarantees smooth, positive closure; eliminates the clatter characteristic of conventional bolt-action mechanisms as they hit the strike. In our opinion, these 58's have the smoothest latching action in the business!

PILFER-PROOF

Unique design insures that the tongue cannot be depressed when the latch is padlocked.

FREE-ACTING HANDLE

The latch action works independently of the handle. Projects from the door only 2-1/64" (51.2mm).

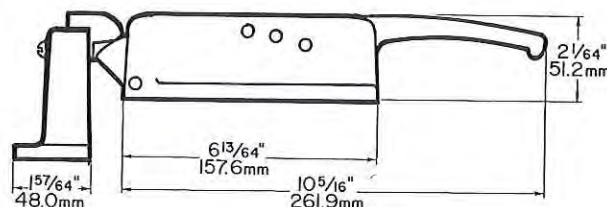
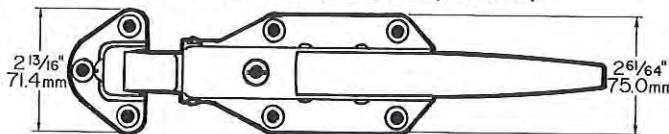

SPECIFICATIONS

Material: Body, handle and strike are high-pressure die-cast zinc.

Finish: Highly-polished chromium-plated, brushed chrome, or baked enamel.

Offsets: Adjustable from :
3/4" (19.1 mm) to 1 1/2" (38.1 mm) above flush

Weight: 3 lbs. (1.36 kg)

4



REFRIGERATION HARDWARE MEDIUM AND HEAVY DUTY HINGES

**R56 SERIES
ADJUSTABLE OFFSET HINGES**

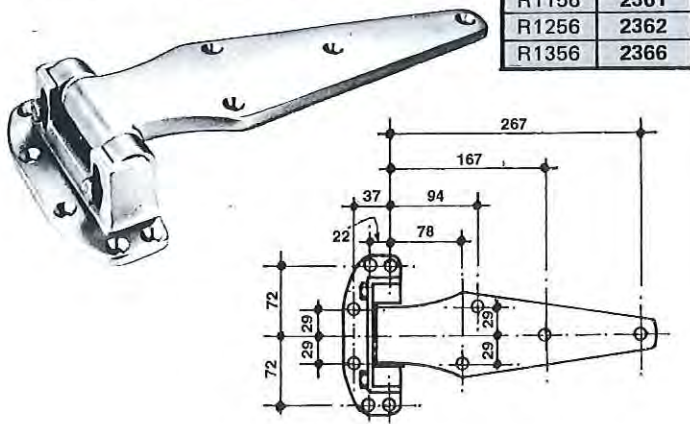

**R74 SERIES
ADJUSTABLE OFFSET HINGES**

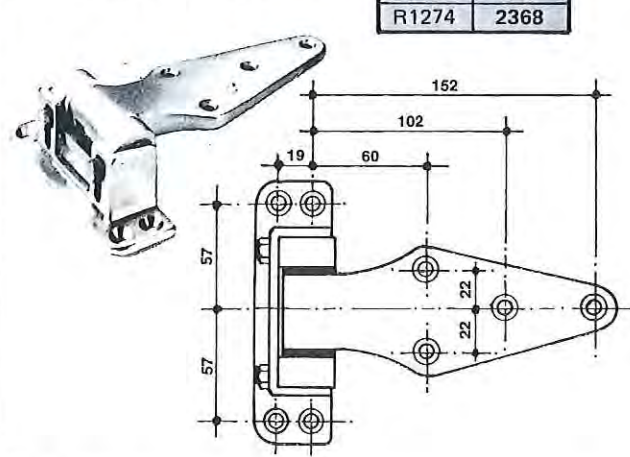

**R76 SERIES
ADJUSTABLE OFFSET HINGES**

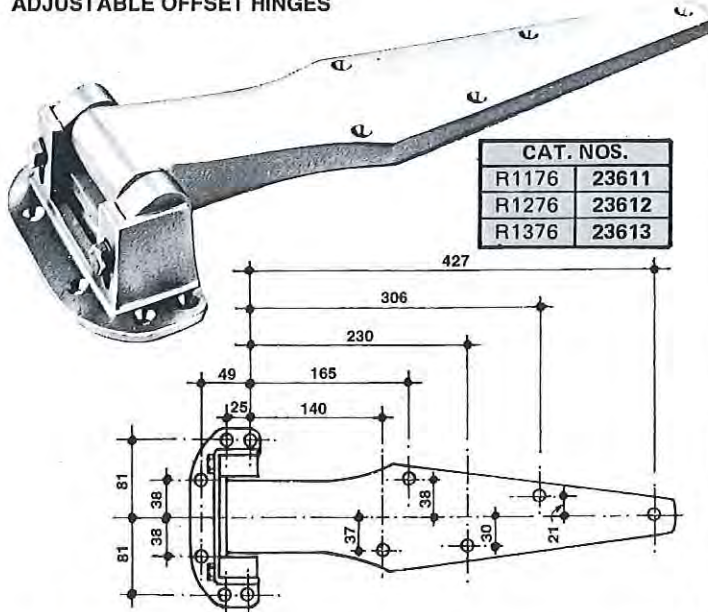

**R75 SERIES
ADJUSTABLE OFFSET HINGES**

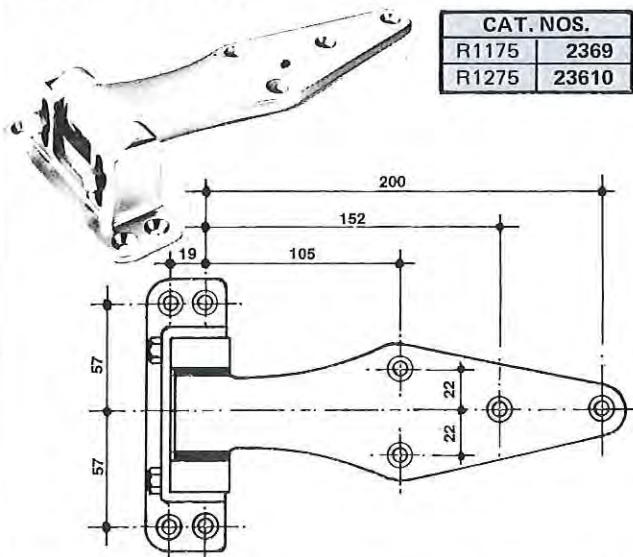

CAT. NO.	NEW P/N	OLD P/N	DESCRIPTION	OFFSET	APPLICATION — OPERATION SPECIFICATIONS	FINISH
R56 SERIES					For use on commercial refrigerators and coolrooms. Adjustable Offset (Blade Length 11" approx.) Body & flap - cast brass. Bushes - delrin. Pin - St. Steel.	CHROME PLATED
2361	R1156	1056R	ADJ. OFFSET	0-16mm		
2362	R1256	1056R	HINGES	16-32mm		
2366	R1356	1056R	(Not handed)	32-48mm		
R74 SERIES					For use on commercial refrigerators and coolrooms. Adjustable Offset (Blade Length 6½" approx.) Body & flap - cast brass. Bushes - delrin. Pin - St. Steel.	CHROME PLATED
2367	R1174	1074R	ADJ. O/S HINGES	0-16mm		
2368	R1274	1074R	(Not handed)	16-32mm		
R75 SERIES					For use on commercial refrigerators and coolrooms. Adjustable Offset (Blade Length 8¼" approx.) Body & flap - cast brass. Bushes - delrin. Pin - St. Steel.	CHROME PLATED
2369	R1175	1075R	ADJ. O/S HINGES	0-16mm		
23610	R1275	1075R	(Not handed)	16-32mm		
R76 SERIES					For use on commercial refrigerators and coolrooms. Adjustable Offset (Blade Length 17½" approx.) Body & flap - cast brass. Bushes - delrin. Pin - St. Steel.	CHROME PLATED
23611	R1176	1076R	ADJ. OFFSET	0-16mm		
23612	R1276	1076R	HINGES	16-32mm		
23613	R1376	1076R	(Not handed)	32-48mm		

All EFCO products shown in this catalogue are manufactured in Imperial sizes
Dimensions shown are nominal Metric equivalents

MEDIUM AND HEAVY DUTY HINGES CONTINUED NEXT PAGE.



REFRIGERATION HARDWARE MEDIUM AND HEAVY DUTY HINGES

R58 SERIES
RISING HINGES

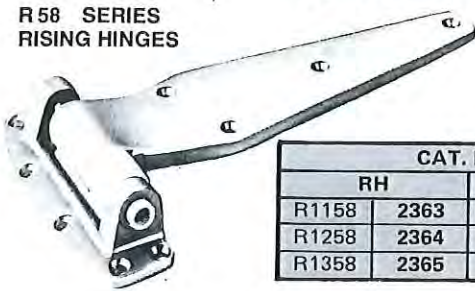

CAT. NOS.			
RH		LH	
R1158	2363	R1158	23620
R1258	2364	R1258	23621
R1358	2365	R1358	23622

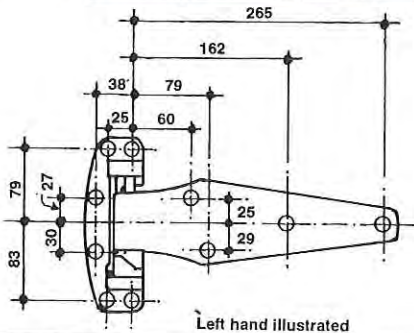

Left hand illustrated

R1080
PIVOT HINGE

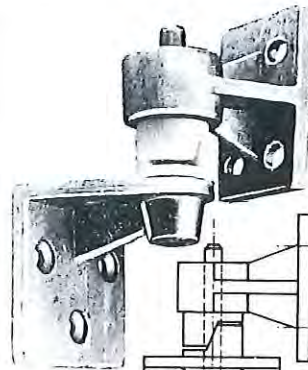

CAT. NO. 23624

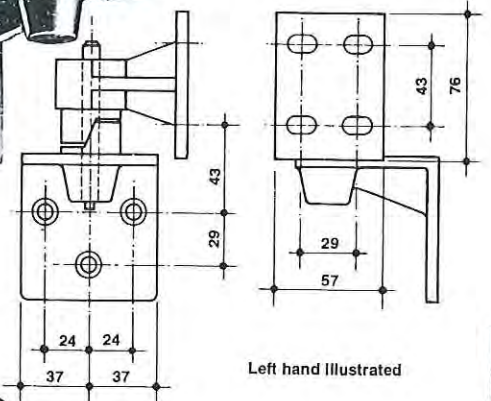

Left hand illustrated

R60 SERIES
RISING HINGES

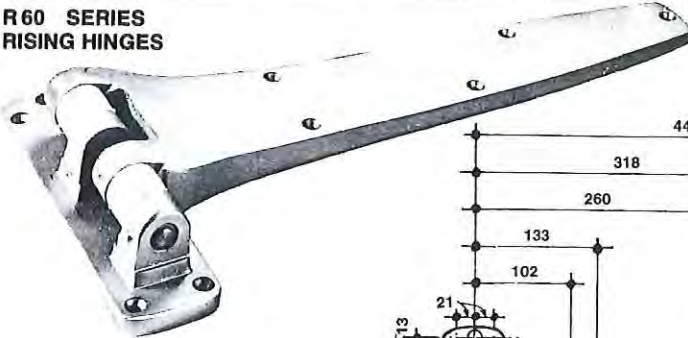

CAT. NOS.	
R1160	23614
R1260	23615

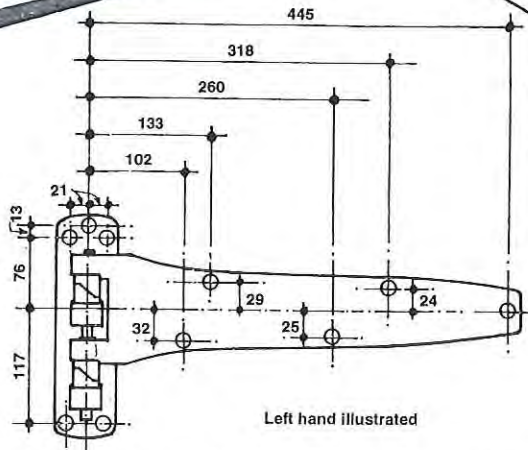

Left hand illustrated

HANDING:

Handed. Please state hand when ordering.

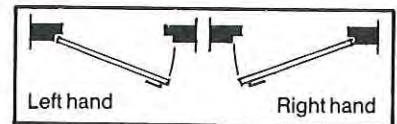

4

CAT. NO.	NEW P/N	OLD P/N	DESCRIPTION	OFFSET	APPLICATION — OPERATION SPECIFICATIONS	FINISH
R58 SERIES						
2363	R1158	1058R	RISING HINGES (RH ONLY)	Flush	Designed for use on commercial refrigs. & coolrooms. Rising flap hinge with fixed offset opens at 180°. Designed to close door from approx. 90° open. Body & flap - cast brass. Rising cams - delrin. Pin - St. Steel.	CHROME PLATED
2364	R1258	1058R		19mm		
2365	R1358	1058R		28mm		
23620	R1158	1058R	RISING HINGES (LH ONLY)	Flush		
23621	R1258	1058R		19mm		
23622	R1358	1058R		28mm		
23619	WR1158RH-V6		Bottom Cam		RH Nylon Bush Set for R58 Series.	
	WR1158RH-V5		Top Cam.			
23618	WR1158LH-V8		Bottom Cam		LH Nylon Bush Set for R58 Series.	
	WR1158LH-V9		Top Cam.			
R60 SERIES						
23614	R1160*	1060R	RISING HINGES (RH & LH)	Flush	For use on large commercial refrigerators & coolrooms. Rising flap hinge with fixed offset opens at 180°. Designed to close door from approx. 90° open. Body & flap - cast brass. Rising cams - delrin. Pin - St. Steel.	
23615	R1260*	1060R		19mm		
23624	R1080*		PIVOT HINGE (RH & LH)	NIL	Designed for use on commercial coolrooms. Face to edge mounting, lift off type. Unequal length pins for ease of mounting. Opens to 180°, rising pivot gives self-closing action from approx. 90° open. Body & flap - aluminium. Rising Cams - delrin. Pin - St. Steel.	NATURAL

* State RH or LH when ordering.

All EFCO products shown in this catalogue are manufactured in Imperial sizes
Dimensions shown are nominal Metric equivalents

NOTES

ONE STOP BUYING

NOW-A-DAYS, THE RELATIVELY HIGH PAY RATES OF MECHANICS AND SERVICEMEN MAKES IT UNECONOMIC TO RUN AROUND TO DIFFERENT SUPPLY HOUSES FOR ODD BALL ITEMS. YOU CAN FIND MOST ANYTHING FOR REPAIR OR INSTALLATION OF REFRIGERATION, AIR CONDITIONING AND HEATING AT YOUR ACPAR CENTRE.

FLEXIBLE DUCTING

ALUMINIUM DUCTING-HAND BENDABLE

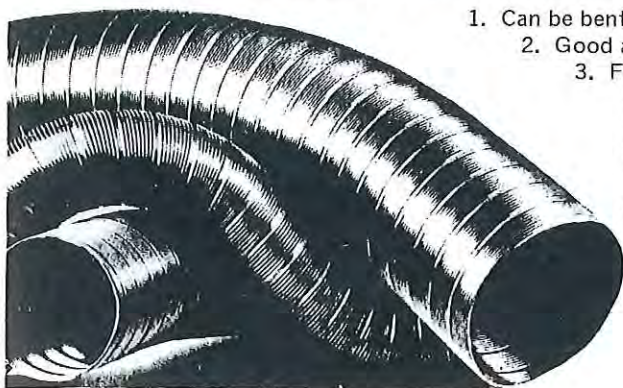

1. Can be bent, straightened, rebent as needed for installation purposes.
2. Good air handling characteristics in air conditioning applications.
3. Friction loss and sound generation values are small.
4. Equally good for both positive and negative pressure applications.
5. Helically corrugated wall gives high resistance to crushing.
6. Bends by hand but is resistant to puncturing and damage.
7. Lightweight, durable and self-supporting in spans.
8. All aluminium construction - is non-combustible.
9. Is easy to cut, couple or connect.

CONSTRUCTION:

The ducting has a single ply wall which is helically corrugated. Seam is 4 ply folded flat and crimped. Average wall thickness is 0.006.



ORDERING DATA

VENTFLEX IS AVAILABLE IN THE FOLLOWING SIZES IN STANDARD 3 m (10 ft) LENGTHS

CAT. NO.	SIZE No.	BENDING RADIUS mm (ins.)
	4	102 (4)
	5	127 (5)
	6	152 (6)
	7	229 (9)
	8	254 (10)
	9	279 (11)
	10	330 (13)
	11	355 (14)
	12	406 (16)

When ordering specify insulated or un-insulated

TENSILE STRENGTH :

All sizes and types of tests to 50 lbs. minimum tensile without rupture.

RUPTURE RESISTANCE FROM BENDING :

The time and cost saving feature of this ducting is its bendability by hand. In normal installations, some adjustment of bends made in the ducting may be needed. The ducting qualities provide for this. It can be sharply bent, straightened and re-bent several times without damage.

The ducting is supplied with or without factory installed Bradford "Tuffskin" insulation.

For further technical details apply for Manufacturers Bulletin available on request.
Also available in Type G - Galvanised Steel and Type S - Stainless Steel.

BORAL INSULWOOL



Glass-Flex SL is a factory fabricated lightweight, flexible air duct with outstanding thermal insulation and acoustical properties. It brings a new meaning to the word "flexible" in the heating and air-conditioning industry in Australia. Glass-Flex SL has the unique property of being compressible lengthwise making possible compressive packaging, so minimising storage and transport costs and largely eliminating loss of product through damage in handling.

Glass-Flex flexible duct is recommended for use as a complete duct system or connector on supply and return air lines in residential, industrial and commercial air-conditioning and ventilating systems; in addition, it can be used as runouts to registers, diffusers and mixing boxes.

GLASS-FLEX SL FLEXIBLE AIR DUCT

SIZE

(a) Diameter

Glass-Flex SL is supplied in nominal diameters listed below.

The duct is made slightly oversize to facilitate installation.

Inside Diameter

GLASS-FLEX SL 25	
CAT. NO.	Nom. Diam. mm (ins.)
23852	100 (4")
23853	125 (5")
23854	150 (6")
23855	175 (7")
23856	200 (8")
23857	225 (9")
23858	250 (10")
23860	300 (12")
23861	350 (14")
23862	400 (16")
23863	450 (18")
23872	500 (20")

(b) Length

All diameters are supplied in standard 3 metre lengths.

Glass-Flex SL is factory fabricated from a resilient helix of zinc coated spring steel wire. It is internally lined with a tough Aluminium laminate, insulated with Insulwool Fibreglass insulation, and jacketed with a tough Polyethylene sleeve.

TEMPERATURE LIMIT

Glass-Flex SL is capable of continuous operation with air temperatures up to 80°C (176°F).

THERMAL INSULATION

























Glass-Flex SL is insulated with Insulwool Fibreglass with minimum Thermal Resistance of 0.6 m² K/W. Nominal thickness of insulation 25 mm.

ALSO AVAILABLE ON APPLICATION

- Glass-Flex SL 50 - 50 mm insulation and polythene jacket
- Glass-Flex 4 Zero 25 - 25 mm insulation and aluminium laminate jacket
- Glass-Flex 4 Zero 50 - 50 mm insulation and aluminium laminate jacket
- Glass-Flex LP181 - un-insulated, with aluminium laminate jacket

REFRIGERATOR DOOR GASKETS

EXTRUDED RUBBER

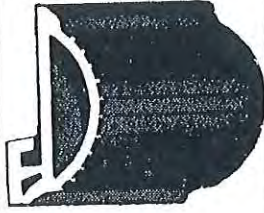
 <p>02 BK 09RG CAT. NO. 2391</p>	 <p>03 BK 09RG CAT. NO. 2392</p>	 <p>04 BK 09RG CAT. NO. 2393</p>	 <p>05 BK 09RG CAT. NO. 2394</p>	 <p>10 BK 09RG CAT. NO. 2395</p>
 <p>11 BK 09RG CAT. NO. 2396</p>	 <p>12 BK 09RG CAT. NO. 2397</p>	 <p>20 BK 09RG CAT. NO. 2399</p>	 <p>21 BK 09RG CAT. NO. 23910</p>	 <p>26 BK 09RG CAT. NO. 23912</p>
 <p>27 BK 09RG CAT. NO. 23913</p>	 <p>28 BK 09RG CAT. NO. 23914</p>	 <p>29 BK 09RG CAT. NO. 23915</p>	 <p>31 BK 09RG CAT. NO. 23917</p>	 <p>32 BK 09RG CAT. NO. 23918</p>
 <p>33 BK 09RG CAT. NO. 23919</p>	 <p>34 BK 09RG CAT. NO. 23920</p>	 <p>36 BK 09RG CAT. NO. 23922</p>	 <p>37 BK 09RG CAT. NO. 23923</p>	 <p>38 BK 09RG CAT. NO. 23924</p>
 <p>39 BK 09RG CAT. NO. 23925</p>	 <p>40 GY 09RG CAT. NO. 23926</p>	 <p>41 BK 09RG CAT. NO. 23927</p>	 <p>42 BK 09RG CAT. NO. 23928</p>	 <p>45 BK 09RG CAT. NO. 23931</p>

20mm (roll)

REFRIGERATOR DOOR GASKET AND CABINET COLLAR RUBBER

EXTRUDED RUBBER

 <p>46 BK 09RG CAT. NO. 2401</p>	 <p>48 BK 09RG CAT. NO. 2403</p>	 <p>49 BK 09RG CAT. NO. 2404</p>	 <p>50 BK 09RG CAT. NO. 2405</p>
 <p>51 BK 09RG CAT. NO. 2406</p>	 <p>52 BK 09RG CAT. NO. 2407</p>	 <p>53 GY 09RG CAT. NO. 2408</p>	 <p>54 BK 09RG CAT. NO. 2409</p>
 <p>55 BK 09RG CAT. NO. 24010</p>	 <p>56 BK 09RG CAT. NO. 24011</p>	 <p>57 GY 09RG CAT. NO. 24012</p>	 <p>PVC 32 BLACK CAT. NO. 24015 WHITE CAT. NO. 24017</p>
 <p>PVC 53 NATURAL CAT. NO. 24016</p>	 <p>HVE 610 2 LEG CAT. NO. 24024</p>	 <p>RU/324 3 LEG - As used on Rudnev Cool Rooms CAT. NO. 24022</p>	 <p>Windlace Fabric Coated Sponge Rubber Cool Room Door Gasket</p> <p>72A 53400 CAT. NO. 24025</p>

4

RF-2 24034



MAGNETIC DOOR GASKETS - REFER NEXT PAGE

MAGNETIC DOOR GASKET FABRICATION SERVICE

We have special facilities for fabricating complete pre-joined Magnetic Door Gaskets to your specification quickly. All we require is a sketch or drawing showing the outside dimensions as illustrated below.

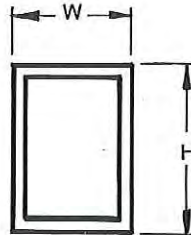

These Magnetic Gaskets are used on the majority of modern domestic refrigerator doors.

- ★ Replaces worn or damaged magnetic door gaskets.
- ★ Replaces obsolete locks and catches.
- ★ Suitable for other appliances where door locks or catches are not fitted.

COMPRISES : A PVC gasket section in 3.96 m (13 ft.) lengths which become magnetic when the matching Magnetic Filler, also in 3.96 m (13 ft.) lengths, is inserted.

Note: Although it is possible to effect joins on site or in the factory, great care and skill is necessary to obtain a clean and precise joint.

With our special facilities you can not only save time but be assured of a top quality job with perfect joints.

	UNIROYAL	RBM
	CAT. NO.	CAT. NO.
DESCRIPTION		
MAGNETIC GASKET complete with FILLER	24031	24031A
MAGNETIC FILLER ONLY 290841	24032	24032A
MAGNETIC GASKET ONLY 290858	24033	24033A

THE DIFFICULT GASKETS WE FABRICATE IMMEDIATELY
THE IMPOSSIBLE ONES TAKE A LITTLE LONGER

Fomofill®

General Purpose Foam

cavity filling foam, seals & insulates

to fill hollow-spaces, holes, joints and cracks, a semi-rigid filler. Excellent adhesion and chemical properties.

FOMOFILL is a general gap filler; in prefab buildings filling gaps in structural elements and skeletal joints, around pipes, joints and bends, around cooling systems. It can also be used for preparing boats and floats; general household renovation and insulation, repair of roofing perimeter and flashing; insulation against heat loss, sound insulation, as reinforcement for finished articles in interior and exterior construction, for pottering, designing and hobby use.

FOMO stops air infiltration, air leakage, adds strength, insulates for heat and sound - **SAVE ENERGY** - use around windows, doors, base plates, siding, sheeting and joints, plumbing fixtures and refrigeration and air conditioning systems

TYPICAL PROPERTIES AT 20°C (68°F) AND 50% RH				
	FOMOFILL		FOMOFIX	
Free Rise Density	27.2 kg/m ³	1.7 lbs/ft ³	32 kg/m ³	2 lbs/ft ³
Appearance	Semi-rigid		Rigid	
Tack Free	20 minutes		30 minutes	
% of Cavity to Fill	40%		40%	
Closed Cell Content	60% to 80%		80%	
Tensile Strength	120 kPa	12.1 PSI	96.5 kPa	14.0 PSI
Elongation at Break	38%		33%	
Shear Strength	39.3 kPa	5.7 PSI	53.1 kPa	7.7 PSI
Dimensional Stability — —15 to 100°C (5 to 38°F)	1—2%		1%	
Water Uptake/Vol.	6%		4%	
K Factor (Aged)	.21		.24	
Shelf Life at 20°C	12 Months		12 Months	
Colour	Amber		Amber	
Toxicity	Non Toxic in normal use			
Adhesion	Good on all surfaces except PE, Teflon & Silicon			
Chemical Resistance	Good to Excellent			
Approx. Foam Vol. per 18oz. Can	15 litres	4 Galls	10 litres	2.8 Galls
" " " 35oz. Can	30 litres	8 Galls	20 litres	5.5 Galls
Cubic Cap. per 18oz. Can	0.5 ft ³		0.4 ft ³	

Fomofix®

Assembly Foam

foamable construction adhesive & sealant

for assembling, sticking, filling, plugging and insulation a rigid assembly foam serving as a foamable construction adhesive with high mechanical properties and an excellent adhesion to other materials

FOMOFIX Assembly Foam is the ideal froth for mounting, fixing, glueing, sealing, thermal and sound insulation of all building materials, bricks, wood, etc.

FOMOFIX has high tackiness for long periods and can withstand high loads. These properties together with its high mechanical workability make FOMOFIX an ideal adhesive for Construction Applications.



TEMPERATURE — ATMOSPHERIC HUMIDITY

During application the temperature of the spray can should be between 68°F-77°F, regardless of the surrounding temperature. Below this requirement, warming in a hand-hot water bath is recommended. Heating above 120°F is strictly to be avoided!

Sufficient atmospheric humidity is important! The foam needs this humidity in order to react well. Deep, dry cavities and those with little air inlet should be slightly moistened to give a damp, though not wet, surface. Remaining dampness disappears upon foam reaction. Too much wetness, however reduces the adhesion and generates voids.

APPLICATION

Take note of the can temperature! Shake the can thoroughly once more. Always keep the valve away from the body, pointing downwards, and begin foaming in the lowest part of cavity.

After extrusion from the nozzle or extension FOAM begins to rise slowly in all directions. The amount extruded more or less triples in size during a period of about 60 minutes. Therefore fill only about 40% of the cavity. A closed skin forms on the surface, which is tack-free after 20-30 minutes. The foam, however, continues to rise slowly.

POST TREATMENT

In less than 24 hours FOMO one-component-polyurethane-foams can be fully trimmed, painted, plastered or finished by conventional methods.

PRODUCT	SIZE	CAT. NO.	YIELD OF FOAM
FOMOFILL	18 oz. Can	2421	Up to 15 Litres (3.3 Imp. Gal.)
	35 oz. Can	2422	Up to 30 Litres (6.6 Imp. Gal.)
FOMOFIX	18 oz. Can	2425	Up to 10 Litres (2.2 Imp. Gal.)
	35 oz. Can	2426	Up to 20 Litres (4.4 Imp. Gal.)

THERMAL INSULATION

POLYURETHANE POURING FOAM - TYPE G

SELF EXTINGUISHING RIGID FOAM FOR BUOYANCY, INSULATION, PACKING, ETC.

The material is supplied in two cans marked A and B. When mixed together in equal proportions foaming occurs, and produces a closed cell structure which sets to form a rigid polyurethane foam of approximate density of 32 to 36 kg/m^3 (2 to $2\frac{1}{4} \text{ lbs/ft}^3$) i.e. each cubic metre or cubic foot of foam will produce 27.3 kg (60 lbs). buoyancy. The foam is not affected by water, oil or petrol. Polyester resin may be applied directly to it, thus making fibreglassing a simple operation, or paints and adhesives may be used on the set foam.

Originally designed for low temperature insulation, the closed cells also make it ideal for use as a buoyancy material, cores in light weight sandwich construction, potting and encapsulation of electric and electronic components, reinforcement, void filling, wreath rings, models, etc. It has also found great use in the making of stage props, because of its strength and lightness. Adhesion to metals, wood and many plastics is excellent.

DIRECTIONS FOR USE:

Into two similar shaped vessels pour equal quantities of A and B, and then pour B (the thinner liquid) into A. Rapidly stir the mixture for approximately 20 seconds by hand (a shorter period if using a mechanical stirrer, such as a mixer fitted to an electric drill) and then pour into the cavity to be filled, distributing as equally as possible over the bottom. Foaming should commence within one minute of first mixing, and the foam will be set within a quarter of an hour. The second layer may then be poured if necessary.

The cavity into which the foam is to be poured should be dry, clean and free from dirt to obtain the best bonding and foam performance. If the space is enclosed, vent holes must be made to allow escape of air, and thus permit the foam to rise. It is better to under-fill and top up afterwards in order to prevent pressures developing. Wax the mould to enable removal after pouring if this is required. Foam will not penetrate paper, and this may be used to cover any parts to be kept clean. Moulds lined with paper allow the block to be lifted out after setting.

Tools, spills of foam etc., may be cleaned with acetone before it sets. The material is difficult to remove from cloth, and old clothes should be worn. Due to the difficulty in cleaning mixing vessels, it is advisable to use disposable containers or those made from polythene, to which the foam will not stick. Plastic cups may be used, but wax containers are not recommended. The resultant density of the foam is in some degree dependant on the amount poured. Small quantities will produce a more dense foam than larger quantities, and so not give the same volume per kg. (lb.). Material allowed to expand freely (open pours) will be less dense than if foaming occurs in confined areas. When pouring in thin panels the following gives an indication of the increase of density to be expected:—

Application	Panel Thickness mm (ins)	Final Density kg/m^3 (lbs/ft ³)	Free Rising Density kg/m^3 (lbs/ft ³)
Refrigerators	25.4 — 38.1 (1 — 1.5)	43.3 — 51.3 (2.7 — 3.2)	32 (2.0)
Freezers	50.8 — 69.9 (2 — 2.75)	38.4 — 44.9 (2.4 — 2.8)	32 (2.0)
Building Panels	38.1 — 61 (1.5 — 2.4)	51.3 — 57.7 (3.2 — 3.6)	32 (2.0)

This increase of density of small pours and in narrow cavities is explained by the breakdown of bubbles to form a skin in contact with the mould which, having higher density, influences the final density of the pour, as it amounts to a greater percentage of the total. This breakdown is again influenced by the temperature of the mould and the thermal conductivity which may drain away the exothermic heat generated and so reduce the heat available to expand the blowing agent. Warm moulds will thus give a less dense foam. Another reason for heavier foams is friction requiring more effort to lift the foam. The optimum temperature for a mould is from 29.4 to 48.9°C (85 to 120°F). It is not desirable to attempt to blow a foam more than 30 cms. ($12"$) in height under normal usage. Pouring foam may be used in conjunction with solid blocks of polyurethane foam, or with buoyancy tanks.

Pouring foam Type "G" is brown in colour. It may be painted if appearance is of importance, and it is recommended that it be covered, particularly if the skin has been cut away in trimming, to expose the cells, as abrasion will break it up. Fibreglass timber or painted canvas may be used. This grade of polyurethane foam is self-extinguishing, i.e., the flame will die out if the source of burning is removed. Naturally, if petrol is spilt on it and ignited, it will burn until the supply of petrol is exhausted.

STORAGE AND TRANSPORT:

As the foam contains a blowing agent which vaporises at a low temperature, it should be kept in a cool place and should not be consigned by air freight because of the lower atmospheric pressures, which could possibly damage the cans. Part A should not be opened when the material is above 21°C (70°F), as loss of the blowing agent may occur.

CLEANING:

As the material is chemically resistant and insoluble once cured, it is essential that cleaning up should be done before this happens. Acetone or lacquer thinners may be used.

SUMMARY:

- (1) Prepare mould or cavity, fencing off with waxed stiff cardboard or similar sheeting.
- (2) Estimate quantity of material to be used, allowing 32 to 36 kg/m^3 (2 to $2\frac{1}{4} \text{ lbs.}$ per cubic foot).
- (3) Measure out A and B in separate containers.
- (4) Pour B into A and mix thoroughly.
- (5) Pour into cavity and distribute before foaming commences. Allow to expand, set, and then top up if necessary.
- (6) Trim if necessary. Break up scraps and include in next pour.

SAFETY PRECAUTIONS:

All foaming operations should be conducted in the open or in well ventilated areas — forced ventilation should be used in confined areas. Avoid breathing of vapours. The use of rubber gloves and goggles or face shield is highly recommended as a precautionary measure. The use of a respirator is imperative in spraying operations. Part B is classified as a toxic material. Avoid contact with skin, eyes or clothing. Avoid breathing of vapours. In case of contact with eyes, flush with plenty of pure water and get immediate medical attention. Wash skin or clothing immediately with alcohol then with plenty of soap and water.

CAT.NO.	AVAILABLE IN
24222	1.25 kg. KITS
24223	2.50 kg. KITS
24224	5.00 kg. KITS
24225	44.00 kg. DRUMS

max temp. 90°C for 3 hrs.

FIGURE THE ODDS

BECAUSE WE BELIEVE OUR STOCK IS ONE OF THE LARGEST AND MOST COMPREHENSIVE IN THE ENTIRE INDUSTRY, THE MATHEMATICAL ODDS OF FINDING WHAT YOU WANT, WHEN AND WHERE YOU WANT IT, HAVE TO BE BETTER AT ACPAR THAN ANYWHERE ELSE.

IF TIME IS MONEY, WHY WASTE IT BY LOOKING ELSEWHERE.

THERMAL INSULATION

Insta-foam[®] froth-pak[®] kits

INSTA-FOAM FROTH-PAK URETHANE offers excellent THERMAL INSULATION VALUES. The thermal insulation qualities of INSTA-FOAM URETHANE at 1.75lbs/cu.ft. are among the best available for today's ENERGY CONSERVATION INDUSTRY.

URETHANE FOAM DISPENSING SYSTEMS FOR:

- ROOF REPAIR • WINDOW-DOOR CAULKING
- TANK REPAIR • REFRIGERATION INSULATION
- CONSTRUCTION JOINTS • RAIL CAR REPAIR
- PIPE FITTINGS - JOINT - ELL'S • VOID FILLER
- REEFER - TRUCK - REPAIR • PACKAGING
- HOPPER CAR SEALANT • BLOCKING BRACING
- DUCT WORK SEALANT • PIPE CHASE CAULKING
- IN-PLACE GASKETING • VIBRATION DAMPENING
- MARINE FLOTATION • BOARD STOCK SEALANT

CAT. NO.	KIT SIZE	BOARD FEET PRODUCED
24210	FP-9.5 (Small Vol.)	9.5
24211	FP-180 (Medium Vol.)	180
	FP-600 (Large Vol.)	600

FROTH-PAK kits are available in three sizes, each complete with all required chemical components, dispensing equipment and instructions

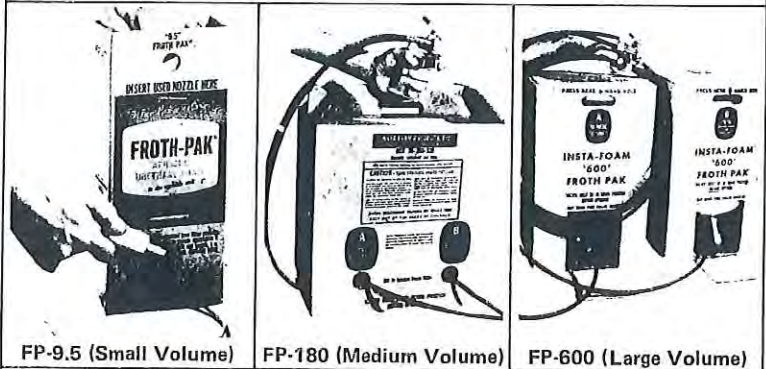

Small-Volume kits are provided with two spray nozzles, each nozzle with a pair of plastic hoses. These attach in the compartment at the bottom of the kit.

Medium & Large-Volume kits include 10 spray nozzles, a gun-and-hose assembly, wrench and a small tube of Vaseline. These are packed in the base of the Medium-Volume kits and in a separate carton with Large-Volume kits.

4

FIXOPUR[®]

Assembling- and filling foam

Product Description

Fixopur is a one-component polyurethane foam in an aerosol can. By pressing the foaming-head, a stream of sticky foam, pre-reacted by a propellant gas, exudes. By absorbing humidity, the foam cures

within about 3 hours depending on the width of the joint. The foam should not be subjected to loads until at least 8 hours after processing. During the first hour, while the foam is still sticky, volume expansion takes place.

CAT. NO.	SIZE	TYPE No.	EXPANDED VOLUME FREE RISE	DENSITY
24220	1 kg. Kit	FP - 1000	Approx. 40 Litres per Can	Approx. 20 kg/m ³

UREPACK Synthetic Resin Pouring Foam Kits

CAT. NO.	KIT SIZE	KIT COMPRISES	FREE CAPACITY	CAT. NO.	KIT SIZE	KIT COMPRISES	FREE CAPACITY
24212	1 Litre	Part A 1 x 500 ml Part B 1 x 500 ml	0.06 m ³ (2 ft. ³)	24214	4 Litre	Part A 1 x 2 Litre Part B 1 x 2 Litre	0.23 m ³ (8 ft. ³)
24213	2 Litre	Part A 1 x 1 Litre Part B 1 x 1 Litre	0.11 m ³ (4 ft. ³)	24215	8 Litre	Part A 1 x 4 Litre Part B 1 x 4 Litre	0.42 m ³ (15 ft. ³)

FINIFIX Expanding Polyurethane Foam Spray Pack

CAT. NO. 2427

750 gram Can

COMPRESSOR SPECIFICATIONS

The following compressor specifications have been compiled from manufacturer data sheets and to the best of our knowledge are correct. However, no responsibility can be accepted for any errors of inaccuracies.

MAKE AND MODEL	BORE INS.	RING WIDTH INS.	PIN DIAM INS.	NO. OF CYLS	SHAFT SIZE INS.	OIL CHARGE PNTS	NO. OF BELTS	H.P. RANGE
BARBERIE								
Single	1.1/4	-	1/2	1	5/8	1/2	1	1/6
Twin	1.1/4	-	1/2	2	5/8	1/2	1	1/4
BRUNNER - (GORDON)								
S140	1.1/2	COMP 3/32 OIL 1/8	1/2	2	11/16	1.3/4	2	1/4 - 1/2
R330	1.13/16	1/8	1/2	2	11/16	1.3/4	2	3/4
R500	2.1/8	1/8	5/8	2	7/8	2.1/4	2	3/4 - 1
R650	2.1/2	1/8	3/4	2	1.1/8	3.1/4	2	1-3
R2002	3.1/4	1/8	3/4	2	1.1/4	4	3-4	2-5
R5002	3.1/4	1/8	3/4	4	1.1/4	6	4	5-10
R10000	4.1/4	1/8C 3/160	1.1/8	4	2	16	5	10-20
R20000	4.1/4	1/8C 3/160	1.1/8	4	2	28	7	20-30
BITZER								
NO.2 COMPRESSOR	1.574	METRIC SIZES		2				
NO.3 COMPRESSOR	1.968			2	18MM.	1.7/8	1-A	3/4 - 1
NO.4 COMPRESSOR	2.559			2	18MM.	1.1/3	1-B	3/4 - 1.1/2
NO.5 COMPRESSOR	3.346			2	20MM.	1.1/3	1-B	1.1/2 - 2
NO.6 COMPRESSOR	4.139			2	30MM.	1.1/3	1-B	2-3
NO.7 COMPRESSOR	4.724			2	35MM.	2.1/4	2-B	2-5
NO.BK2 COMPRESSOR	4.724			2	40MM.	3.1/2	2-B	2-5
GOLDSTREAM-BELT DRIVEN								
CH	1.9/16	-	* 1/2	1	1/2	1.1/8	1	1/6
KB	1.3/4	-	* 1/2	1	1/2	1.1/4	1	1/4 - 1/3
P	1.9/16	-	* 1/2	2	7/8	2.3/4	1	1/3 - 1/2
Q	1.3/4	-	* 1/2	2	7/8	2	2	3/4 - 1
M	2	-	* 1/2	2	7/8	2	2	1 - 2
T-TB	2	-	* 1/2	2	7/8	2.1/4	2	2 - 3
J-JB	2.5/16	ALL MODELS COMP 3/32 OIL - 1/8	* 1/2	2	7/8	2.3/8	2	3 - 5
R, Prior to 1948	2.9/16		3/4	2	15/16	4.3/4	3	3 - 5
RO	3.1/16		3/4	2	1.1/8	5	3	5
O, Prior to 1948	3.1/16		3/4	2	15/16	4.3/4	3	2 - 3
OB	3.1/16		3/4	2	1.1/8	5	3	7.1/2 - 10
GOLDSTREAM-SEMI-SEALED								
CY	1.9/16			1		3/4		1/6
KY	1.9/16			1		3/4		1/3
BY	1.9/16			1		3/4		1/2
NY	1.9/16			1		3/4		3/4
NX	2			1		3/4		1.1/2
BU	2			2		2		2
NU	2			2		2		3
NZ	2.1/4			1		3/4		2 - 3
NE	2.1/4			2		2.1/2		3
EMMGO (EARLY MODELS)								
A,E4	1.1/2	1/8	7/16	1	5/8	1/2	1	1/6
C,CD,SC	1.1/2	1/8	7/16	2	5/8	1	1	1/4
B	1.11/16	1/8	7/16	1	5/8	1/2	1	1/4
D,ED	1.11/16	1/8	7/16	2	5/8	1	1	1/3
SE,SEF	1.13/16	1/8	1/2	2	5/8	2	2	1/2 - 3/4
DE	2	1/8	7/16	2	5/8	1	1	1/3
DX	2	1/8	1/2	2	5/8	1.1/2	1-2	1/3 - 1/2
E,EF	2	1/8	1/2	2	5/8	2	2	1/2 - 3/4
SF	2.1/4	1/8	1/2	2	3/4	2	2	1
F,FF	3	3/16		2	7/8	3	3	2 - 3
EMMGO (LATER MODELS)								
R,L	1.1/4	-	1/2	1	5/8	1	2	1/8 - 1/6
S,	1.1/4	-	1/2	2	5/8	1.1/2	1	1/4
G,K	1.1/4	-	1/2	2	5/8	1.1/2	1	1/4
AS,RS	1.1/2	-	1/2	1	5/8	1/3	2	1/6 - 1/4
J,M	1.1/2	-	1/2	2	5/8	1.1/2	1	1/3
CS	1.1/2	-	1/2	2	5/8	7/8	1-2	1/4 - 1/3
ES	1.13/16	1/8	5/8	2	7/8	1.3/4	2	1/2 - 3/4
N,P	1.13/16	1/8	5/8	2	7/8	2.3/4	2	3/4 - 1
T	2.1/4	1/8	3/4	2	1.3/16	3.1/4	2	1.1/2
U	2.3/4	3/16	3/4	2	1.3/16	3.1/4	2	2 - 3
Q	3.1/4	3/16	1	2	1.3/8	5	2	3 - 5

* Original equipment pin - Actual diameter .490".

USE ACPAR PARTS TO HELP YOU BUILD REFRIGERATION SYSTEM RELIABILITY

4

COMPRESSOR SPECIFICATIONS

MAKE AND MODEL	BORE INS.	RING WIDTH INS.	PIN DIAM. INS.	NO. OF CYLS.	SHAFT SIZE INS.	OIL CHARGE PINTS	NO. OF BELTS.	H.P. RANGE
ECKERSLEY (ZERO-HEAT)								
A	1.1/2	1/8	-	2	5/8	1.1/2	1	1/4
B	1.5/8	1/8	-	2	5/8	1.1/2	1	1/3
BH	1.13/16	1/8	-	2	5/8		1	1/2
C2, D2	2	1/8	-	2	7/8	5.1/2	2	3/4 - 1
E2, F2	2.3/8	1/8	-	2	7/8	5.1/2	3	1.1/2 - 2
EE2, FF2	2.3/8	1/8	-	4	1	10.1/2	4	3 - 4
ELLIS & JUDGES								
A	1.5/8	1/8	1/2	2	5/8	3/4	1	1/3
AA	1.3/4	1/8	1/2	2	5/8	3/4	1	1/2
B	1.7/8	1/8	1/2	2	3/4	2	2	1/2
C	2.1/4	1/8	1/2	2	3/4	2	2	3/4
D	2.1/4	1/8	1/2	4	3/4	4	2	2
E	2.1/4	1/8	1/2	6	3/4	6	2	3
CC	2.3/8	1/8	1/2	2	3/4	2	2	1
DD	2.3/8	1/8	1/2	4	3/4	4	2	2 - 3
EE	2.3/8	1/8	1/2	6	3/4	6	2	5
TP	1.3/4	-	9/16	2	1	2	2	1 - 5
VP	1.3/4	-	9/16	4	1	2	3	2 - 7.1/2
FRIGIDAIRE								
ADO16/25, AFO20/25	1.1/4	-	-	2	5/8	1/2	1	1/6
A4/5, 547/8, 748	1.1/2	-	-	2	5/8	1/2	1	1/6
A/AF125	1.1/2	-	-	2	5/8	1	1	1/4
A,B,G,S, early	1.1/2	-	-	2	5/8	1.1/4	1	1/4 - 1/3
AD/AF133	1.1/2	-	-	2	5/8	1.1/4	1	1/3
AF250/375, AD/WD2	1.3/4	1/8	-	2	15/16	2.7/8	1 - 2	1/2 - 1
N.Y.	1.7/8	1/8	-	2	5/8	2.7/8	1	1/3
N,O	2.1/8	1/8	-	2	5/8	2.7/8	1	1/2
AD/WD4, AF4100	2.1/8	1/8	-	2	15/16	2.1/2	2	1.1/2
AD/WD6	2.1/2	1/8	-	2	15/16		2	2 - 3
JACK FROST (GORDON)								
OR	1.5/8	1/8	7/16	2	5/8	1.1/2	2	1/4 - 1/2
R	2	1/8	1/2	2	3/4	2.1/2	2	1/2 - 3/4
R4	2	1/8	1/2	4	29/32	4	3	1.1/2 - 2
RA	2.1/4	3/16	9/16	2	13/16	3	2	1 - 1.1/2
RA4	2.1/4	3/16	9/16	4	29/32	5	3	2 - 3
BV4	2.1/2	3/16	11/16	4	15/16	3	5	5 - 7.1/2
HALLMARK								
2A	1.3/8	-	3/8	2	3/4	1.1/2	-	1/3
2B	1.5/8	-	1/2	2	13/16	2	-	1/2 - 3/4
2C	2	-	9/16	2	15/16	3	-	3/4 - 1
3C	2	-	9/16	3	15/16	4	-	1 - 2
2D	2.1/2	1/4	3/4	2	1.5/16	5	-	2
3D	2.1/2	1/4	3/4	3	1.5/16	6	-	3
4D	2.1/2	1/4	3/4	4	1.5/16	8	-	4 - 5
TW1	4	5/16	1.1/4	2	1.7/8	12	-	6 - 10
TW2	4	5/16	1.1/4	3	1.7/8	14	-	8 - 12
JOMOCO								
RC-13	1.1/4	-	1/2	1	5/8	3/4	1	1/6
RC-50	1.1/4	-	1/2	2	5/8	1.1/8	1	1/5 - 1/4
RC-19	1.1/2	-	1/2	1	5/8	3/4	1	1/6 - 1/5
RC-30	1.1/2	-	1/2	2	5/8	1.1/8	1	1/3
RC-60	1.11/16	-	1/2	2	5/8	1.1/8	1	1/2
KELVINATOR								
SA	1.1/4	-	1/2	1	5/8	3/4	1	1/6
SB, SSB	1.1/4	-	1/2	2	5/8	1.1/2	1	1/4
SG, SS G	1.1/2	-	1/2	2	5/8	1.3/4	1	1/3
H,GH	1.11/16	-	1/2	2	5/8	1.1/4	1	1/3 - 1/2
PFBA	1.13/16	1/8	5/8	2	5/8	1.3/4	2	3/4
K	2.1/4	1/8	3/4	2	7/8	3	2	3/4 - 1
Y	2.3/4	1/8	3/4	2	1.3/16	3.1/4	2	1.1/2 - 2
T	3.1/4	3/16	1	2	1.3/8	4.7/8	2	3 - 5
83	3.150			3			3B	10 - 15
84	3.150			4			4B	15 - 20
86	3.150			6			4B	20 - 25

MAKE IT AN ACTROL PART — YOU'LL APPRECIATE THE SERVICE AND BACKING

COMPRESSOR SPECIFICATIONS

MAKE AND MODEL	BORE INS.	RING WIDTH INS.	PIN DIAM. INS.	NO. OF CYLS.	SHAFT SIZE INS.	OIL CHARGE PINTS	NO. OF BELTS	H.P. RANGE
Kirby — Tecumseh — Belt Driven								
HG 1000	1.7/8			2	7/8	325 C.C.	1	—
CG (HGC)	1.7/8			2	7/8	325 C.C.	2	3/4 — 2
CH (VFT)	1.3/4			4	1	739 C.C.	2	2 — 3
CJ (VFTL)	1.3/4			4	1	1478 C.C.	2	2 — 5
P (N.L.A.)	2.1/2			3	1.1/4	7.1/2 PTS	2	3 — 5
CK (RA)	3.1/4			3	1.1/4	8 PTS	4	5 — 10
CM (SA)	4			3	2.1/4	14 PTS	6	10 — 20
Terry (Belt Driven)								
E	1.515	—	1/2	1	1/2	1	1	1/6
K	1.515	—	1/2	2	3/4	3/4	2	
VL	1.515	—	1/2	2	5/8	1.1/4	1	1/3
BR	1.5/8	—	1/2	1	1/2	1	1	3/4
YL	1.5/8	—	1/2	2	5/8	1.1/4	1	1/2
D	1.5/8	—	1/2	2	5/8	2.1/4	2	1/2 — 3/4
C	1.3/4	—	1/2	1	5/8	1.1/8	1	1/3
X	1.3/4	—	1/2	2	5/8	1.1/4	1	3/4
U, UHR, ETC	1.7/8	—	1/2	2	15/16	1.1/4-2.1/4	2	1 — 1.1/2
RR, RRF	2"	—	9/16	2	15/16	2.1/4	2-3	5 — 1.1/2
A, J, F, P	2.3/4	1/8	7/8	2	1.3/16	3.1/2	3	2 — 10
V4, V4S	2.3/4	1/8	7/8	4	1.3/8	4.1/2	5	5 — 20
KU	1.656	3/32	5/8	2	1.5/16	1	2A	1 — 2
RA	2.25	1/8	11/16	2	1.1/4	2.75	3A	2 — 5
PJ	2.75	1/8	7/8	2	1.1/4	3.5	3B	3 — 10
PJS	2.75	1/8	7/8	2	1.1/4	3.5	3B	3 — 10
JY	2.75	1/8	7/8	2	1.1/4	3.5	3B	3 — 7 1/2
PY	2.75	1/8	7/8	2	1.1/4	3.5	3B	5 — 10
VS	2.75	1/8	7/8	4	1.3/8	4.5	4B	7 1/2 — 15
Terry-Comef (Belt Driven)								
65				2	16 MM	1	1 — A	3/4 — 1.1/2
125				2	20 MM	2.1/2	2 — A	1 — 2
200				2	20 MM	3.1/3	2 — A	2 — 4
355				2	25 MM	3.2/3	3 — A	3 — 5
Terry — Semi Sealed								
SX Series	1.3/8			1		1		
SD Series	1.5/8			1		1		
TY Series	1.3/8			2		1		
TR Series	1.515			2		1		
TM Series	1.5/8			2		1.3/4		
TG, TL, Series	1.7/8			2		1.3/4 — 3		
G, Q, QG Series	1.7/8			4		4.1/2 — 5		
R2 Series	2			2		3		
R4 Series	2			4		4.1/2		
Universal Cooler								
A, AA	1.1/2	1/8	7/16	1	15/16	1	1	1/6
CC, DD	1.1/2	1/8	7/16	2	15/16	1	1	1/4
FF	1.3/4	1/8	7/16	2	15/16	1	1	1/3
J Standard Twin	1.13/16	5/32	9/16	2	15/16	1	1	1/3
K Super Twin	2.1/4	5/32	9/16	2	15/16	2	1	1/2 — 3/4
L Royal Twin	2.1/4	5/32	9/16	2	15/16	2.7/8	1	3/4 — 1
M Master Twin	2.1/4	5/32	9/16	2	1.1/4	4.3/4	2	1 — 1.1/2
N Imperial Twin	2.1/4	5/32	9/16	2	1.1/4	5.1/4	2	1.1/2 — 2
P Standard 3 Cyl.	2.1/2	1/8		3	1.1/4	7.1/2	2	2 — 3
R Super 3 Cyl.	3.1/4	1/8		3	1.1/4	8	4	3 — 5
VELOC								
No. 2 Compressor								
3 Compressor								
4 Compressor								
5 Compressor								
6 Compressor								
7 Compressor								
SEE BITZER								
WERNER — BELT DRIVEN								
G	1.5/8	1/8	7/16	2	11/16	1.1/2	2	1/3
JR, JJ	1.5/8	1/8	7/16	2	11/16	1.3/4	2	1/3
D	1.5/8	1/8	7/16	2	11/16	2.1/4	2	1/3
JB	1.3/4	1/8	7/16	2	11/16	1.3/4	2	1/2
M, N, NM	2	1/8	5/8	2	11/16	1.1/2	2	1/2 — 3/4
PP	2	1/8	5/8	2	1	4	2	3/4 — 1
Z	2	1/8	5/8	2	1	3.1/2	3	1
Y, RY	2.1/2	1/8	5/8	2	1	3	4	3
W, RW	2.1/2	1/8	5/8	3	1	3.1/2	3	1.1/2
YY	2.3/4	1/8	5/8	2	1	2.1/4	4	3
WW	2.3/4	1/8	5/8	2	1	2.1/2		2
H-W	3.1/4	3/16	1	2	1.1/4	4	3	4
T-LT	3.1/4	3/16	1	3	1.1/4	5	3	5 — 7.1/2
SS	3.1/16	Comp 3/32	3/4	2	1	2.3/4	3	5
TV	3.1/16	Oil 5/32	3/4	4	1.1/4	6	4	10
TT	2.1/4	1/8	3/4	2	1.3/16	3	2	1 — 1.1/2
UU	2.3/4	1/8	3/4	2	1.3/16	3.1/4	2	1.1/2 — 2
QQ	3.1/4	3/16	1	2	1.3/8	4.7/8	2	3 — 5

4

BITZER COMPRESSORS AND CONDENSING UNITS

FOR R12 AND R502

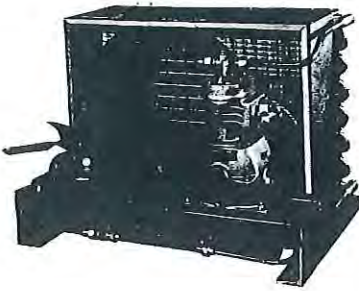

Bitzer compressors are constructed according to the counter flow principle and are the result of over 30 years' experience in the manufacture of refrigerating and air-conditioning machinery. The compressors are adaptable for R12, R22 and R502 applications with the respective range of the application being contingent on the speed of rotation of the compressor. Compressors Type 6 and 7 are provided with a screw-in thread for a heating cartridge in the oil sump. The cartridge is supplied as an extra.

All compressors from Type 3 up are equipped with bronze bearings and from Type 4 up with piston rings. All surfaces and bearings are accurately honed to fine limits to guarantee long life and trouble-free service.

FURTHER TECHNICAL DETAILS AND ENGINEERING RECOMMENDATIONS ON APPLICATION.

GENERAL COMPRESSOR SPECIFICATIONS (APPROXIMATE TO NEAREST ORIGINAL METRIC VALUES)

CAT. No.	MANUF. MOD. No.	BORE ins.	STROKE ins.	No. OF CYLS	PUMPED VOL. cu.ft/Rev.	SPEED RANGE		OIL CHGE Imp. pts.	SERVICE VALVES		FLY WHEEL		CONNECT. N.P.T.F.	
						Min.	Max.		Disch.	Suct.	Diam. O.D'	G.R.-Sect.	Gauge	Oil Ret.
2531	2	1.574	1.181	2	0.002652	450	1000	1.0	1/2 FL.	1/2 FL.	10 1/4"	1-B	1/8	1/8
2532	3	1.968	1.574	2	0.005538	430	1000	1.5	1/2 FL.	5/8 FL.	10 1/4"	1-B	1/8	1/8
2533	4	2.559	1.968	2	0.011710	350	740	2.2	1/2 FL.	3/4 FL.	15"	2-B	1/8	1/8
2534	5	3.346	2.362	2	0.02403	300	590	3.5	3/4 FL.	7/8 SL.	17 3/4"	2-B	1/8	1/8
2535	6	4.139	2.953	2	0.04596	300	550	8.5	7/8 SL.	2-7/8 SL.	17 3/4"	3-B	1/8	1/2
2536	7	4.724	3.346	2	0.06782	350	505	10.6	1 SL.	2-1/8 SL.	19 11/16"	4-B	1/8	1/2
2537	BK-2	4.724	2.598	2	0.05268	750	1300	10.6	1 1/2 SL.	2 1/8 SL.	19 11/16"	5-B	1/4	1/4

CONDENSING UNIT SPECIFICATIONS AND CAPACITIES — REFRIGERANT 502

CAT. No.	COMPRESSOR				CAPACITY B.T.U./HR. AT SATURATED SUCTION GAS TEMPERATURE °F.										
	MANUF. MOD. No.	COND. SIZE	R.P.M.	C.F.H.	-45	-35	-25	-15	-10	-5	0	+5	+10	+15	
25311	2-02	E32	500	80	730	1065	1430	1890	2170	2470	2780	3170	3475	3855	
25312			900	143	1314	1917	2574	3402	3906	4446	5004	5706	6255	6939	
25313	3-02	E32	675	224	2092	2943	4010	5366	6156	7020	7898	8843	9855	10868	
25314			675	224											
25315	4-02	E33	900	299	2790	3924	5346	7155	8208	9360	10530	11790	13140	14490	
25316			590	415	4002	5616	7620	10820	11810	13320	15120	17100	19200	21360	
25317	4-02	E42	740	520	4936	6926	9398								
25318			740	520					12580	14578	16428	18648	21090	23680	26340
25319	5-02	E43	415	600	5810	8176	10956	14359	16185	18343	20833	23282			
25320			500	721	7200	9850	13200	17300	19500	22100					
25321	5-02	E53	550	792	7700	10835	14520	19030	21450						
25322			590	851	8400	11820	15840	20760							
25323	5-02	E54	415	600							25100	28050	31700	37150	
25324			500	721							24310	27610			
25325	5-02	E54	550	792						23400	26520				
25326			590	851									30855	34870	40865
25327	5-02	E55	550	792							30120	33660	38040		
25328			590	851											44580
25329	6-02	EH66	590	851											
25330			350	965	9205	12985	17430	23205	26425	29995					
25331	6-02	E55	415	1144	11288	15936	21373	28345	32370	36728					
25332			500	1379	13150	18550	24900	33150							
25333	6-02	E66	550	1517	14465	20405	27390								
25334			350	965								33775	37800	43950	48200
25335	6-02	EH66	415	1144							41293	46480	49800	53950	
25336			500	1379						37750	42850	48250	54000	58500	63500
25337	6-02	EH66	550	1517					36465	41525	47135	53075	59400		
25338			550	1517										64350	69850
25339	7-02	EH66	420	1709	16674	23646	31668	41160	46200	52920	59640				
25340			420	1709									67200	72660	79800
25341	7-02	E76	490	1994	19850	28150	37700	49000	55000	63000	71000	80000	86500		

NOTE.—R12 CAPACITIES FOR UNITS WITH COMPRESSORS 2-12 TO 7-12 CONTINUED OVERLEAF
CAPACITIES BASED ON 90°F. AMBIENT AIR TEMP. (BASIC UNITS 105°F. CONDENSING), 5°F. LIQUID SUB-COOLING AND ADEQUATE HEAT EXCHANGE CONDITIONS TO ENSURE MODERATE AND DRY SUPERHEATED SUCTION GAS RETURN INTO COMPRESSOR.
FOR EACH 10°F. INCREASE IN AMBIENT AIR TEMPERATURE, DECREASE CAPACITY BY APPROX. 6%.

QUICK AS A FLASH

AND VERY CAREFUL. THAT'S OUR ORDER DEPARTMENT. WHETHER YOUR ORDER IS LARGE OR SMALL, IT WILL RECEIVE PROMPT AND EXACTING ATTENTION. WE DESPATCH OVER 90% OF ALL ORDERS ON THE SAME DAY THEY ARE RECEIVED.

BITZER COMPRESSORS AND CONDENSING UNITS

FOR R12 AND R502

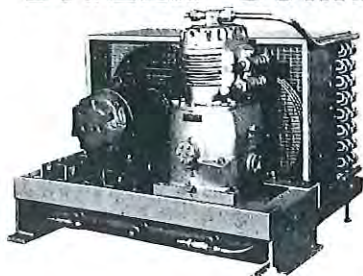

Bitzer condensing units are manufactured in a range of sizes and types to suit all applications from 1/2 to 35 H.P.

The compressors are twin cylinder and the condenser sizes can be varied to cover applications from -30°F. to +45°F. using the same size compressor. B.T.U. output is in accordance with the speed of the compressor.

All units have heavy steel frame, integral liquid receiver and belt guard for complete protection.

A Catalogue Number is given for every combination. Once having made your selection you only need to quote the catalogue number to obtain your exact requirement.

FURTHER TECHNICAL DETAILS AND ENGINEERING RECOMMENDATIONS ON APPLICATION.

CONDENSING UNIT SPECIFICATIONS AND CAPACITIES — REFRIGERANT 12

CAT. No.	COMPRESSOR				CAPACITY B.T.U./HR. AT SATURATED SUCTION GAS TEMPERATURE °F.										
	MANUF. MOD. No.	COND. SIZE	R.P.M.	C.F.H.	-30	-20	-10	0	+10	+20	+25	+35	+40	+45	
2541	2-12	E32	600	95	1026	1260	1614	2184	2796	3600	4176	5406	6420	7140	
2542			755	120	1283	1583	2018	2730	3495	4500	5220	6758	8025	8925	
2543			970	154	1659	2037	2609	3531	4520	5820	6751	8740			
2544			970	154										10379	11543
2545	3-12	E32	430	143	1406	1896	2550	3294	4214	5289	5934	7353	8170	8858	
2546			590	196	1929	2596	3499	4519	5782	7257	8142	10089			
2547			755	251	2453	3308	4448	5745	7350	9220					
2548			810	269	2649	3572	4803	6205							
2549		970	322	3172	4277	5752	7430								
25410		E33	590	196									11210	12154	
25411			755	251							10350	12825	14250	15450	
25412			810	269					7938	9963	11178	13851	15390	16686	
25413	970		322					9506	11931	13386	16587				
25414	4-12	E42	445	313	3074	4118	5544	7216	9240	11616	13112				
25415			590	415	4390	5522	7430	9676	12390	15576					
25416			740	520	5506	6926	9324	12136							
25417		E43	445	313								16280	17776	19404	
25418			590	415							17582	21830	23836	26019	
25419			740	520					15540	19536	22052				
25420	E53	740	520								27380	29896	32634		
25421	5-12	E53	310	447	4557	5921	7936	10354	13516	17484	19561	24056	27590		
25422			405	584	5954	7736	10368	13527	17658	22842					
25423			500	721	7350	9550	12800	16700	21800						
25424		550	793	8085	10505	14080	19470								
25425		E54	405	584							25556	31428	36045		
25426			500	721						28200	31550				
25427	550		793					23980	31020	34705					
25428	E55	405	584										38273		
25429		500	721								38800	44500			
25430		550	793								42680				
25431	6-12	E55	310	855	9920	11470	15000	19220	24955	31620	35340				
25432			355	979	11200	12950	16940	21735	28175						
25433			465	1282	14720	17020	22264	28520							
25434			500	1379	16000	18500	24200	31000							
25435			550	1517	17600	20350	26620								
25436			E66	310	855								43400	48670	
25437		355		979						35700	39900	49000			
25438		465		1282					37030	46920	52440				
25439		500		1379					40250	51000					
25440		550		1517				34100	44275						
25441		EH66		310	855										53940
25442			355	979									54950	60900	
25443	465		1282								64406				
25444	500		1379								57000				
25445	550		1517							56100	62700				
25446	E76		465	1282									72200	80000	
25447		500	1379								70000	78500	87000		
25448		550	1517								77000	86350	95700		
25449	7-12	E66	365	1485	14400	18900	25236	33120							
25450			420	1709	16800	22050	29442								
25451			500	2035	19900	26250									
25452			365	1485					42480	52920	57960				
25453		EH66	420	1709				38682	49560	61740					
25454			500	2035			35050	46050							
25455			365	1485								75640	79920	90720	
25456			420	1709							67620	83580	93240	105840	
25457	E76	500	2035						59000	73500	80500	99500			

4

CAPACITIES BASED ON 90°F. AMBIENT AIR TEMP., 110°F. CONDENSING TEMP., 5°F. LIQUID SUB-COOLING AND ADEQUATE HEAT EXCHANGE CONDITIONS TO ENSURE MODERATE AND DRY SUPERHEATED SUCTION GAS RETURN INTO COMPRESSOR. FOR EACH 10°F. INCREASE IN AMBIENT AIR TEMPERATURE DECREASE CAPACITY BY APPROX. 6%.

WE HAVE LARGE STOCK HOLDINGS OF PARTS FOR YOUR SUPERCEDED EQUIPMENT

COLDSTREAM COMPRESSORS AND CONDENSING UNITS

OPEN TYPE - BELT DRIVEN

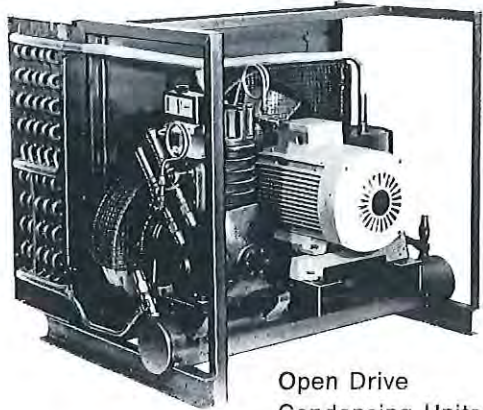

Open Drive Condensing Units

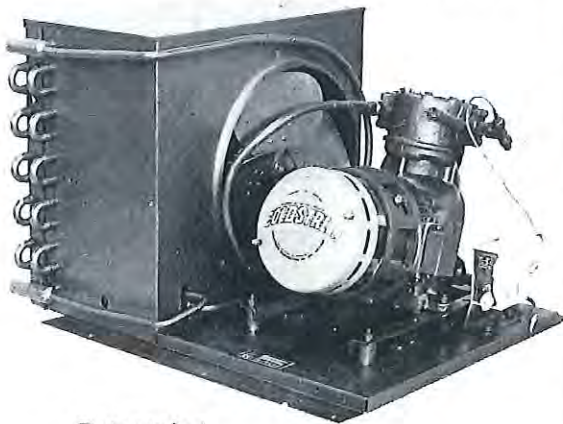

Rotosealed Condensing Units

COMPRESSOR SPECIFICATIONS

CAT. NO.	MODEL	HP RANGE	NO. CYLS.	BORE INS.	STROKE INS.	SWEPT VOL. c.ms/rev	OIL CHARGE PINTS
2554	JB	3-5	2	2.31	2.75	23.1	2.38
2555	RO	7.5	2	3.06	2.5	36.9	5
2556	OC	7½-10	2	3.06	3.5	51.6	5

CONDENSING UNIT SPECIFICATIONS — R12

CAT. NO.	UNIT MODEL	COND MODEL	COMP RPM	MOTOR HP	CAPACITY — SUCTION TEMP.			
					-30°F (-34.4°C)	0°F (-17.8°C)	+20°F (-6.7°C)	+40°F (+4.4°C)
25520	OC430	G36	860	10	18620	36270	54200	—
25521	OC400	G36	800	10	17280	33750	50500	—
25519	OC360	F30	720	7.5	15550	30330	45400	69300
25518	OC300	F24	600	7.5	12930	25290	37900	57700
25517	OC240	E18	480	5.5	10370	20250	30300	46200
25516	RO300	F24	800	5.5	12930	25290	37900	57700
25515	RO240	E18	640	7.5	10370	20250	30300	46200
25514	RO180	E12	480	4	7770	15180	22720	34650
25513	JB160	C11	730	4	6910	13500	20200	30800
25545	JB128	C11	600	3	5530	10800	16200	24600
25512	JB110	C11	500	3	4750	9270	13900	21200
25546	JB090	C11	410	2	3890	7580	11370	17340

ROTOSEALED-ELECTRO MAGNETICALLY DRIVEN

COMPRESSOR SPECIFICATIONS

CAT NO.	MODEL	NO. CYLS.	BORE INS.	STROKE INS.	Swept Vol. c.ft/rev	Oil Charge Pints
25551	CD	1	1.56	0.63		0.75
25552	HD	1	1.56	0.94		0.75
25553	LX	1	2.00	0.88	0.75	0.75
25554	AX	1	2.00	1.19	1.00	0.75
25555	AZ	1	2.25	1.19	1.50	0.75
25535	NZ	1	2.25	1.50	2.00	0.75
25537	NU	2	2.00	1.50	3.00	2.00
25538	NE	2	2.25	1.50	4.00	2.50

CONDENSING UNIT SPECIFICATIONS — R12

CAT. NO.	UNIT MODEL	COND MODEL	MOTOR TYPE	MOTOR CAPACITY — SUCTION TEMP.				
				NOM HP	-30°F (-34.4°C)	0°F (-17.8°C)	+20°F (-6.7°C)	+40°F (+4.4°C)
25559	LX-F2	F2	Single Phase 240V	3/4	1550	3060	4700	7115
25560	AX-H3	H3	50CY Three Phase 415V	1	2100	4140	6340	9630
25561	AZ-J4	J4		1.1/2	2690	5300	8120	12310
25562	AX-H3	H3		1	2100	4140	6340	9630
25563	AZ-J4	J4		1.1/2	2690	5300	8120	12310
25564	NZ-G5	G5	2	3370	6620	10150	15410	
25565	NU-A11	A11	3	5380	10600	16260	24670	
25566	NE-G13	G13	4	6730	13250	20300	30830	

All Capacities in BTU/HR based on 90°F (32.3°C) ambient with design range condenser.

COLDSTREAM COMPRESSOR "CHANGE-OVER" SERVICE

We provide a Change-Over Facility on many Coldstream Compressors

- Open Drive Models
- Rotosealed Models
- Stators for Rotosealed Models

Details supplied on request

Note: Available in Victoria only

SUPERSEDED COLDSTREAM EQUIPMENT — Reference purposes only

COMPRESSORS OPEN TYPE — BELT DRIVEN

MODEL	HP RANGE	NO. CYLS.	BORE INS.	STROKE INS.	OIL CHARGE PINTS
G	1	2	1.75	1.5	2
M	1½-2	2	2	1.5	2
TB	3	2	2	2.5	2¼

ROTOSEALED-ELECTRO MECHANICALLY DRIVEN

MODEL	NO. CYLS.	BORE INS.	STROKE INS.	HP	OIL CHARGE PINTS
CY	1	1.562	0.625	1/3	3/4
KY	1	1.562	0.75	1/2	3/4
BY	1	1.562	1.062	1/2	3/4
NY	1	1.562	1.5	3/4	3/4
BU	2	2.0	1.062	3	2

CONDENSING UNITS OPEN TYPE — BELT DRIVEN

UNIT MODEL	RPM	Liq. Rec. Capac. lbs.	CAPACITY — BTU/HR. SUCT. TEMP. °F			
			-20	0	+20	+40
Q39/130	610	15	2100	3500	5500	8700
M60/130	700	15	3200	5300	8400	13400
M75/190	895	15	4000	6700	10500	16700
TB99/200	730	18	5400	8900	14000	22300

ROTOSEALED — ELECTRO MECHANICALLY DRIVEN

UNIT MODEL	RPM	Liq. Rec. Capac. lbs.	CAPACITY — BTU/HR. SUCT. TEMP. °F			
			-20	0	+20	+40
KY18/55	1425	5	950	1600	2500	4600
BY26/74		5	1400	2300	3650	5800
NY36/84		5	1950	3200	5000	8000
BU90/176		13	4800	8000	12600	20000



HERMETIC COMPRESSORS



CAT. NO.	TYPE	DETAILS	CODE No.	Capacity Watts	Displac. cm ³ /rev.
TYPE TL COMPRESSORS — OIL COOLED					
	TL3A/LST M/LBP	With oil only	102B2004	54	3.13
	TL4A/LST M/LBP	With oil only	102B2005	70	3.86
257100	TL5A/LST M/LBP	With oil only	102B2010	96	5.08
TYPE FR COMPRESSORS — OIL COOLED					
25793	FR7.5A/LST LBP	With oil cool. coil	103L2714	125	6.93
25794	FR8.5A/LST LBP	With oil cool. coil	103L2814	145	7.95
25796	FR8.5A/LST LBP	With oil only	103L2804	145	7.95
25795	FR8.5B/HST H/LBP	With oil only	103L2854	555	7.95
25797	FR8.5B/LST H/LBP	With oil cool. coil	103L2864	555	7.95
25798	FR10A/LST M/LBP	With oil cool. coil	103L2914	165	9.05
TYPE SC COMPRESSORS — OIL COOLED					
25799	SC10B/HST H/LBP	With oil only	104L2510	770	10.30
25765	SC12A/LST LBP	With oil cool. coil	104L2680	225	12.90
25783	SC12B/HST H/LBP	With oil only	104L2670	960	12.90
25787	SC15B/HST H/LBP	With oil only	104L2830	1115	15.30
25788	SC18B/HST H/LBP	With oil only	104L2110	1275	17.70
25768	SC21B/HST H/LBP	With oil only	104L2310	1485	20.95
TYPE BD2.5 COMPRESSORS — 12 & 24 VOLT D.C.					
25789	BD2.5 M/LBP	12 Volt. D.C.	102Z3010	40	
25790	BD2.5 M/LBP	24 Volt. D.C.	102Z4010	40	

KELVINATOR COMPRESSORS

OPEN TYPE — BELT DRIVEN



CAT. NO.	COMP. MODEL	NOM. HP	NO. OF CYLS.	BORE INS.	STROKE INS.	DISP. MENT CU. IN. REV.	OIL CHGE PINTS	SERVICE VALVES		FLY-WHEEL DIAM. INS.
								SUCT.	DISCH.	
2571	SG	1/3	2	1.1/2	1.5/16	4.7	1.1	1/2"	3/8"	10
25771	H	1/2 - 3/4	2	1.11/16	2	7.5	1.8	5/8"	3/8"	12.1/2
2573	K	1 - 1 1/2	2	2.1/4	2.1/2	17.9	3.3	5/8"	1/2"	16.3/8
2574	Y	2 - 3	2	2.3/4	3.1/2	41.5	4.4	1"	5/8"	20.1/4
2575	T	5	2	3.1/4	4	66.4	6.2	1.1/4"	1"	20.1/4
2572	H42		2	1.11/16	2	8.9	1.8	5/8"	1/2"	
25772	K62		2	2.1/4	2.1/2	19.9	3.3	3/4"	5/8"	
25773	Y72		2	2.3/4	3.1/2	41.5	4.4	1"	3/4"	
25774	T82		2	3.1/4	4	66.4	6.2	1.1/4"	1"	

ELLIS & JUDGES COMPRESSORS

Main features and specifications of the TP and VP are as follows —

Two Compressors only covering a range from 1 to 7 1/2 H.P. on R12, R22, R500 and R502.

Speed range up to 1700 R.P.M. suitable either for belt drive or direct drive.

Positive displacement oil pump and large 40oz oil reservoir.

Bearings of "CLIVITE" 25 for high speed and long life.

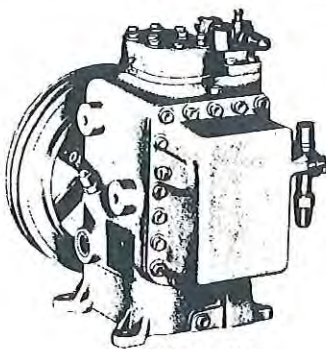

MODEL TP TWIN CYLINDER

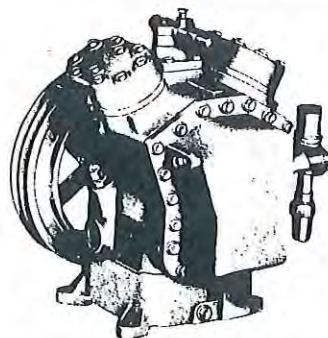

MODEL VP FOUR CYLINDER

COMPRESSOR SPECIFICATIONS AND CAPACITIES

MODEL	H.P. RANGE	BORE INS.	STROKE INS.	No OF CYLS	DISP. MENT CU. IN. REV.	OIL CHGE	FLYWHEEL		COMP REVS.	CAPACITY BTU/HR AT SUCT. TEMP °F							
										R12				R22			
										-20	0	+20	+40	-20	0	+20	+40
TP	1-5	1.3/4	1.3/4	2	8.4	40 oz	10.1/2"	2 - B	500	1650	3100	5500	8400	2000	4100	7500	13000
									1000	3900	6200	10600	17000	4900	9100	15700	25500
									1500	5000	9200	15800	27600	8000	15000	24000	37500
VP	2-7.1/2	1.3/4	1.3/4	4	16.8	40 oz	10.1/2"	OR - B 3	500	3300	6200	11000	16800	4000	8200	15000	26000
									1000	7800	12400	21200	34000	9800	18200	31500	51000
									1500	10000	18400	31600	55200	16000	30000	48000	75000

CAPACITIES BASED ON CONDENSING TEMP. 100 F.